

DYNEX  
**PALLISIDE®**

Traditional Profile  
Drained Cavity

**INSTALLATION GUIDE**

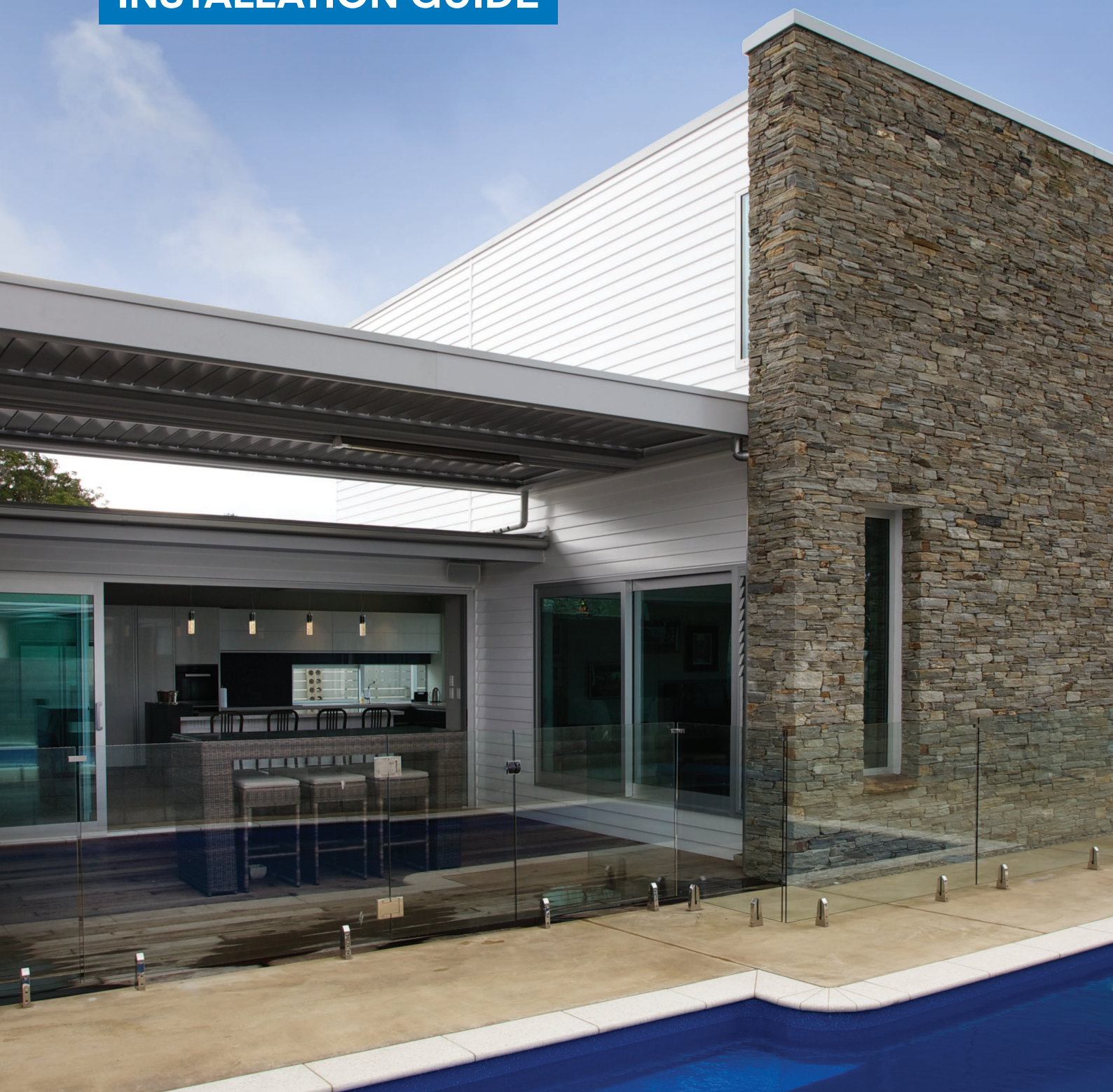



## CONTENTS

1.0	Installation Preparation	2
1.1	Handling and Storage	2
1.2	Tools	2
1.3	Temperature	2
1.4	Board Cover	2
1.5	Fixings	3
2.0	Installation Procedure	5
2.1	Critical Joinery Set-out	5
2.2	Cavity Batten Layout	7
2.3	Installation of Base Accessories and Trims	7
2.4	External Corner Options	9
2.5	Internal Corner	12
2.6	Non-Standard and 135° Corners	13
2.7	Weatherboard Installation	13
2.8	Jointing Options	15
2.9	Installation at Joinery	17
2.10	Installation at Soffit	20
2.11	Below Joinery Finishing Options	22
2.12	Joinery Finishing Options	24
3.0	Additional Installation Information	25
3.1	Solvent Cement	25
3.2	Finishing Paint	25
3.3	Steel Frame Configuration Table	26
3.4	Additional Details	27

# 1.0 Installation Preparation

## 1.1 Handling and Storage

### On-site Storage

Palliside® should be stored away from areas prone to excess dirt and debris. Cartons should be kept out of the exposed weather. This is to protect the product from damage in case there is surplus material at the end of the job that you would like credited.

### Opening Packs

Palliside® weatherboards come in packs of two lengths. To remove weatherboards from the pack, carefully cut through the full length of sleeve (boards in pack face inwards) and lift each weatherboard out.

### Safe Handling

Where possible it is recommended that two people carry out handling and fixing of Palliside®. Beware of any awkward movements, straining or twisting while moving long lengths of Palliside®. Packs of board should be lifted, not dragged.

### Sunscreen

When handling Palliside® weatherboard and accessories, care should be taken to ensure hands are free from sunscreen residue, which if comes into contact with the board may leave a visible print or mark.

## 1.2 Tools

Palliside® requires no special tools and can be cut and nailed like timber, using a wide variety of standard building equipment.

## 1.3 Temperature

Palliside® should be installed between 10°C to 25°C. Avoid fixing Palliside® in temperature extremes.

## 1.4 Board Cover

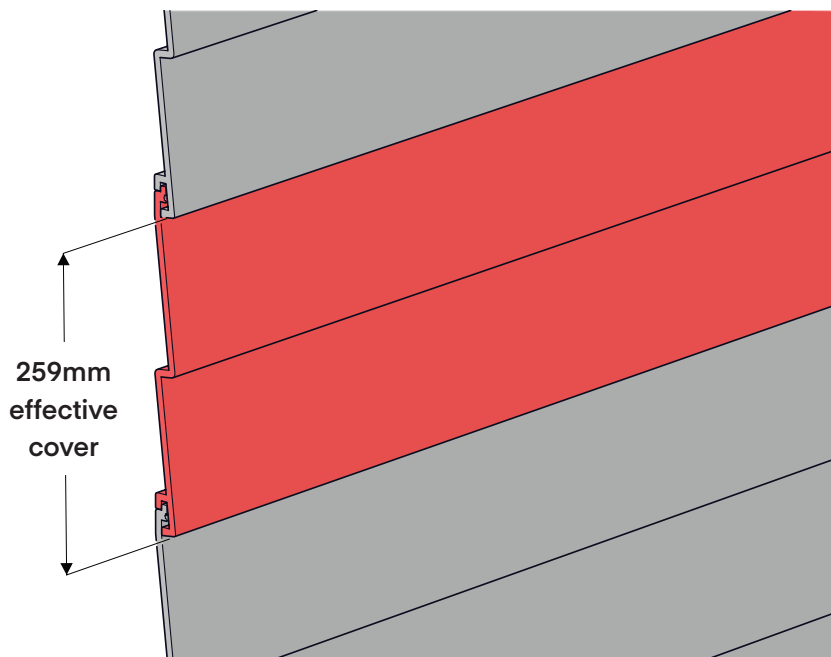

Palliside® is a double-profile weatherboard with a total effective cover of 259mm.

Use the traditional profile pre-cut scribe as a storey rod (or create one using timber) to help maintain board alignment.

## 1.5 Fixings

### Fixings for Palliside® - Drained Cavity Timber Frame

Fixing Type	Installation Method		
	Over Structurally Fixed Battens	Over Non-Structurally Fixed Battens	
	Windzone Up to and Including VH	Windzone Up to and Including VH	Windzone EH and above
<b>Manual Nailing</b>	The HDG 40mm x 2.5mm Palliside® nail must be used (fixed at maximum 600mm centres). The Palliside® nail has been specially designed with a smaller (5mm) head. 5 kg boxes of Palliside® nails are available as part of the standard range of accessories.	60mm x 2.8mm HDG flat head nails must be used (fixed at maximum 600mm centres). Such nails can be sourced from your preferred Building Merchant.	60mm x 3.15mm Annular Groove type HDG flat head nails must be used (fixed at maximum 400mm centres). Such nails can be sourced from your preferred Building Merchant.
<b>Impulse Driven Nails</b>  A nailing tool such as a Paslode finishing nailer can be used to fix Palliside® weatherboards.	Paslode ND50mm SS304 grade brads, or equivalent (2 per stud, skewed, at a maximum spacing of 600mm centres). (ITW/ Paslode product code B20054).	Paslode ND60mm SS304 grade brads, or equivalent (2 per stud, skewed, at a maximum spacing of 600mm centres). (ITW/ Paslode product code B20054).	n/a
<b>Screws</b>  Palliside® may be fixed using screws.	8-gauge x 32mm SS304 grade countersunk square drive wood screws or equivalent. (MSL/Fortress Code SFQX 832).  Under Window Accessories - Class 4 or above 8Gx20 pan head screws.	8-gauge x 50mm SS304 grade countersunk square drive wood screws or equivalent. (MSL/Fortress Code SFQX850).  Under Window Accessories - Class 4 or above 8Gx20 pan head screws.	8-gauge x 65mm SS304 grade countersunk square drive wood screws or equivalent. (MSL/Fortress Code SFQX865).  Under Window Accessories - Class 4 or above 8Gx20 pan head screws.
<b>Longer Length Boards</b>  For custom made lengths longer than 6.3m.	The HDG 40mm x 2.8mm <b>Annular Groove</b> nail must be used (fixed at maximum 600mm centres).	The HDG 60mm x 2.8mm <b>Annular Groove</b> nail must be used (fixed at maximum 600mm centres).	60mm x 3.15mm Annular Groove type HDG flat head nails must be used (fixed at maximum 400mm centres).  Such nails can be sourced from your preferred Building Merchant.

### **1.5.1. Fixing in Sea Spray Zones**

Due to the Palliside® unique hidden nailing system and anti-capillary groove, there is no requirement to use stainless steel nails when fixing Palliside® in Zone D locations as specified in NZS 3604. The specification of Class 4 fixings in accordance with AS 3566 must be used, or minimum SS304 stainless in the absence of a HDG option. In these locations, any fixings that are to be exposed and not hidden by the weatherboard interlock, must be a minimum SS316 grade.

### **1.5.2. Microclimatic Conditions**

Microclimatic conditions, including geothermal hot spots, industrial contamination and corrosive atmospheres, and contamination from agricultural chemicals or fertilisers can convert mildly corrosive atmosphere into aggressive environments for fasteners. The fixing of Palliside® weatherboards in areas subject to microclimatic conditions requires specific design in accordance with NZS 3604 Paragraph 4.2.4.

### **1.5.3. Curved Walls**

When Palliside® is to be installed to a curved wall, the weatherboard needs to be screwed in place using 8-gauge SS304 grade countersunk square drive screw (MSL/Fortress Code SFQX832) or equivalent. Minimum wall radius 3m.

### **1.5.4. Steel Frames**

Steel framing must comply with NASH Standard Part Two for buildings or parts of buildings within the scope limitations of NASH Standard Part Two, or to a specific design. For full details refer Palliside® Technical Guide and Steel fixings section of this document.

## 2.0 Installation Procedure

### Pre-line Checklist

- › The building underlay is lapped and fixed correctly
- › Flashing tape has been applied to the base of the sill and to all corners of window and door openings
- › Timber framing is straight and studs are inline

### 2.1 Critical Joinery Set-out

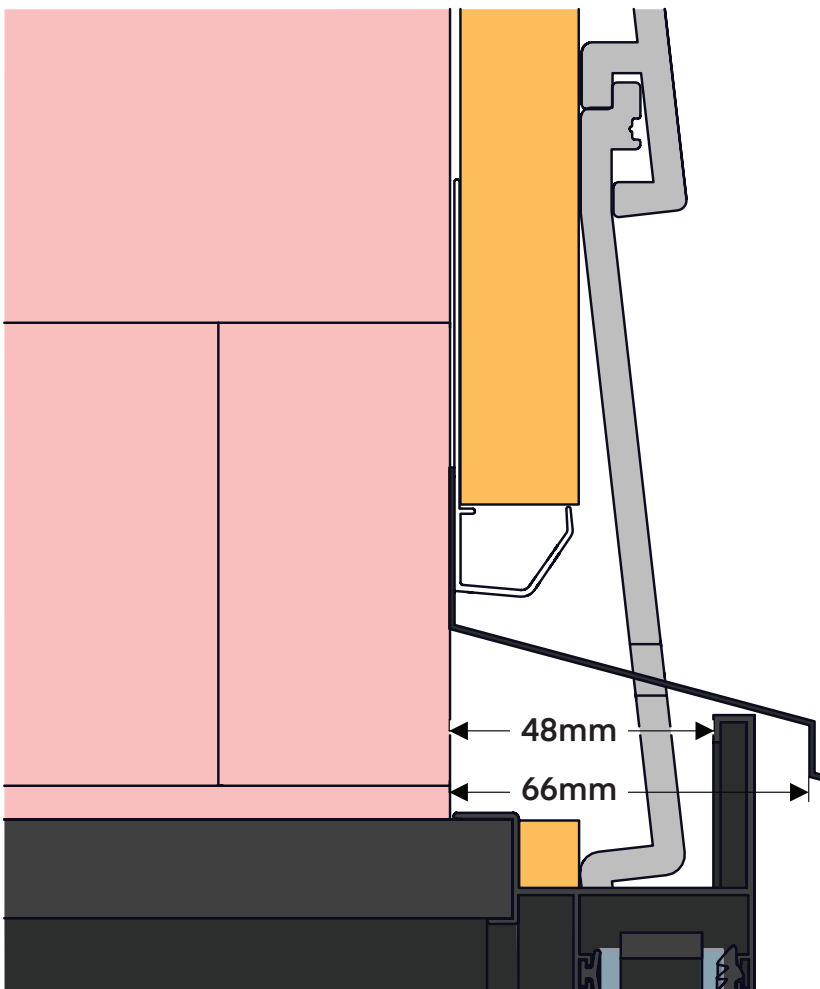

Palliside® finishes require strict adherence to joinery set-out to take into consideration the effect of things like the build-up of flashing tape at corners of openings.

48mm min. distance between back of drained cavity to inside of lapped joinery.

66mm min. distance between back of drained cavity to inside of head flashing flange.

Refer to Palliside® Technical Guide and detail DC-01-T for more information.

Aluminium joinery and associated head flashings must be installed by the building contractor in accordance with the Palliside® Technical Literature.

A 7.5-10mm nominal gap must be left between the joinery reveal and the wall framing so an air seal with in accordance with Acceptable Solution E2/AS1, Paragraph 9.1.6 or NASH Building Envelope Solutions, Paragraph 9.1.6 can be installed after the joinery has been secured in place.

### 2.1.1. Installation of WANZ Bar

Fix the WANZ bar (or custom packer) at maximum 600mm centres before installing joinery where required.

**FIX**

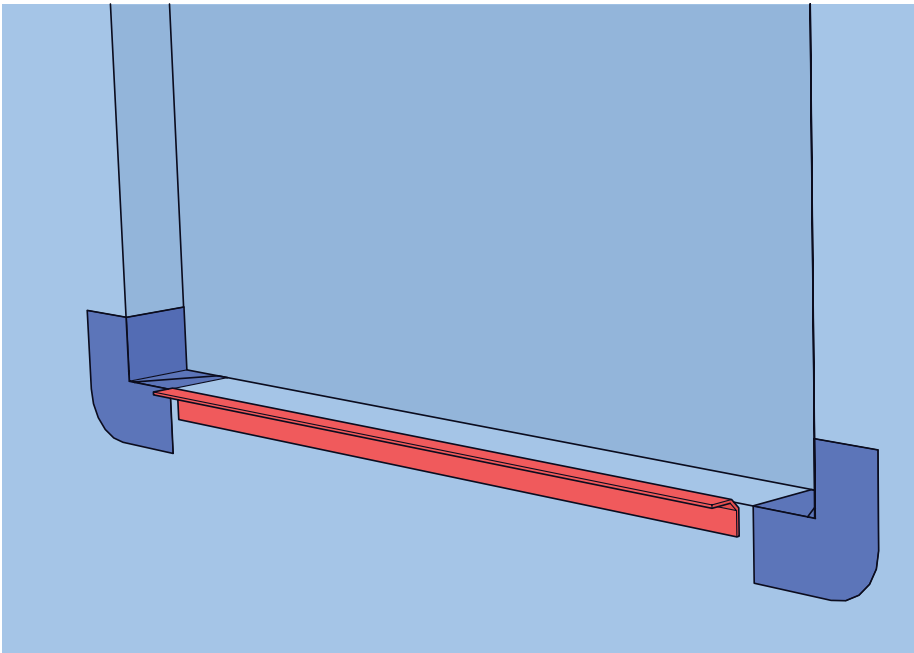

**Note:**

Cut WANZ support bar to be 100mm from each side of opening.

WANZ bar supplied by others.

### 2.1.2. Installation of Head Flashing

Once joinery is in place, the aluminium head flashing (supplied by others) is fixed to the building wrap face of the cavity and the drained cavity is then finished using a drained cavity closer. If using facings around joinery, the head flashing width may be reduced. Refer to the Palliside® Traditional Profile Joinery Facings Installation Guide for more information.

**FIX**

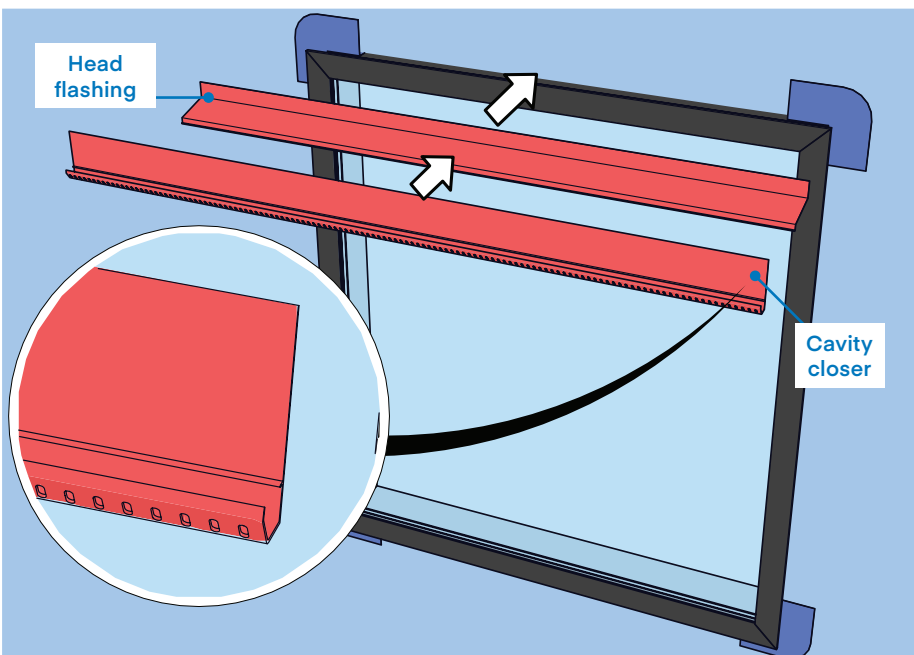

**Note:**

Head flashing carried min. 40mm past joinery each side to allow for scribes. Nail at 300mm centres and cover width with flashing tape at building wrap. Apply sealant at either end of the head flashing to form a head flashing stop end.

Fix cavity closer over top of head flashing (see detail DC-01-T).

## 2.2 Cavity Batten Layout

Vertical battens must be installed at a maximum 600mm centres. A continuous horizontal batten is permissible at the soffit only.

Horizontal spacers are required to allow horizontal Palliside® starting trims to be fixed at the required 300mm centres providing they are:

- › A maximum 100mm in length
- › Installed with a minimum slope of 5°
- › Spaced at least 100mm away from any vertical batten or edge of window opening

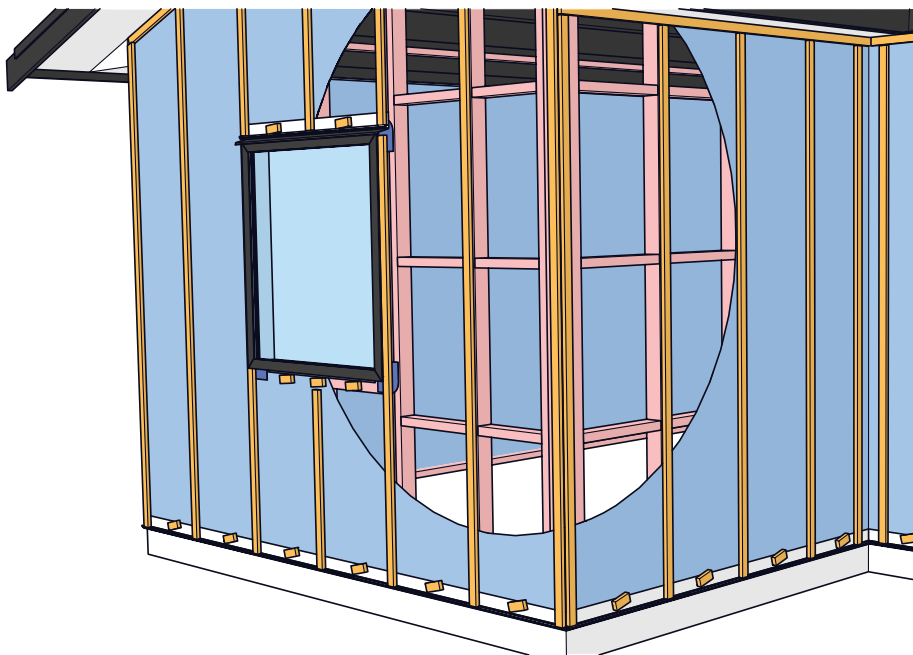

## 2.3 Installation of Base Accessories and Trims

the installation of weatherboards, all base accessories need to be fixed in place.

Base accessories include all starting pieces, all corner base pieces, and the two-part jointer base. Boxed corner finishes also need to be installed prior to the weatherboard.

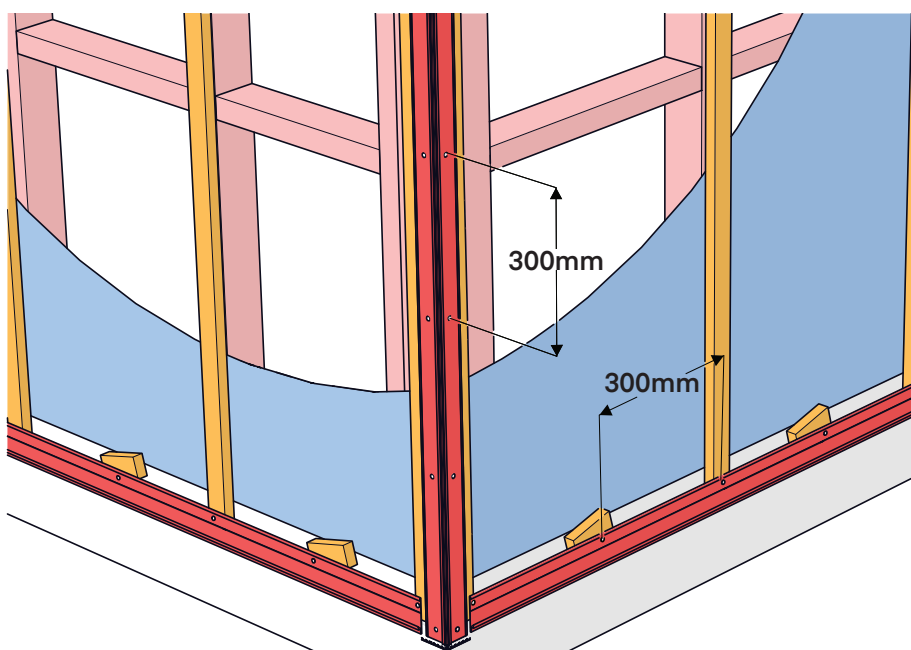

### Note:

- › Fix all base accessories at 300mm centres
- › Ensure all horizontal starting options are level (crucial with starter strip)
- › Ensure all horizontal base accessories are left slightly short of corner option base pieces and vertical trims (not overlapped)
- › Mitre trims where required



Palliside® starter strip should be installed with a minimum 50mm weatherboard overhang in accordance with requirements of the NZBC. Starter strip cannot be used when starting with part board, or along raked areas.

### 2.3.1 Starter Strip Concrete Foundation

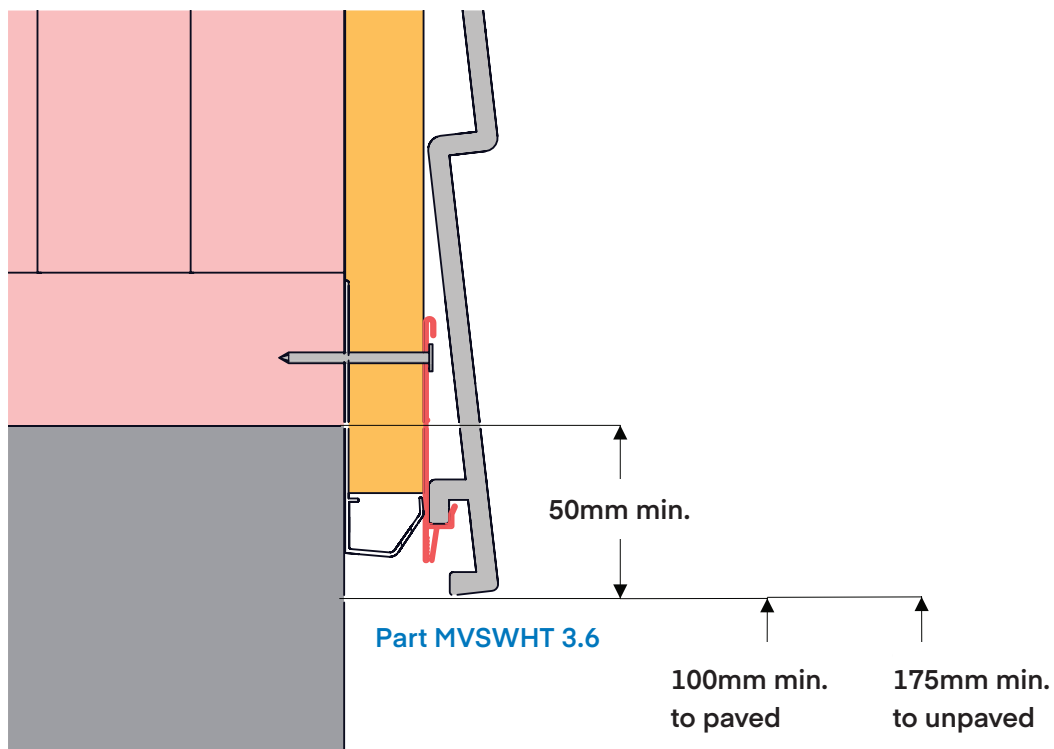

### 2.3.2 Starter Strip Timber Floor

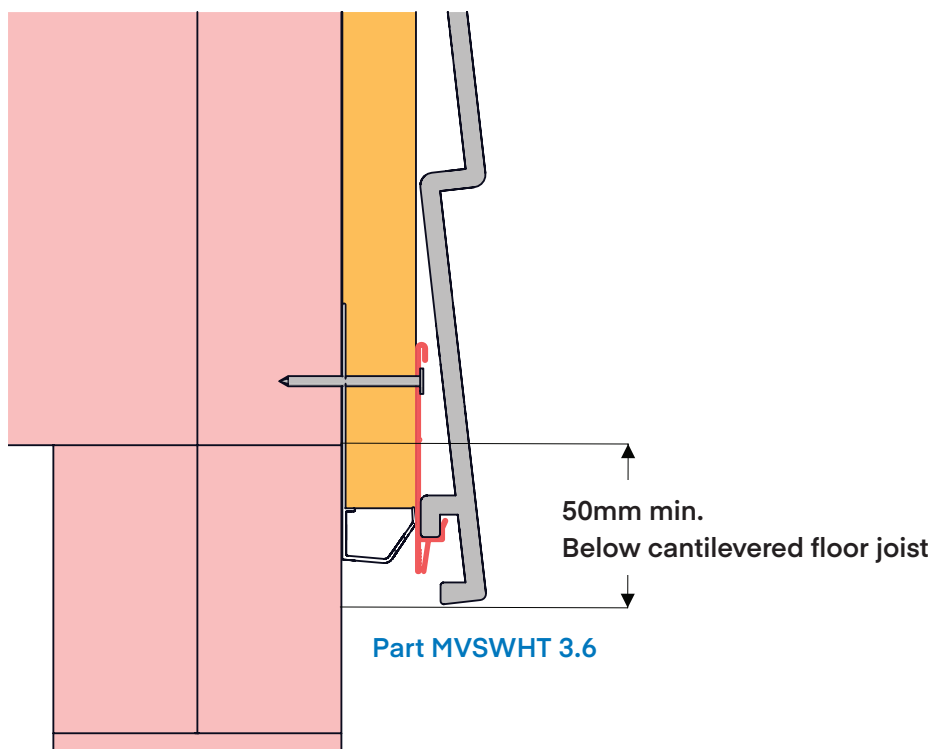

### 2.3.3. One Part Trim

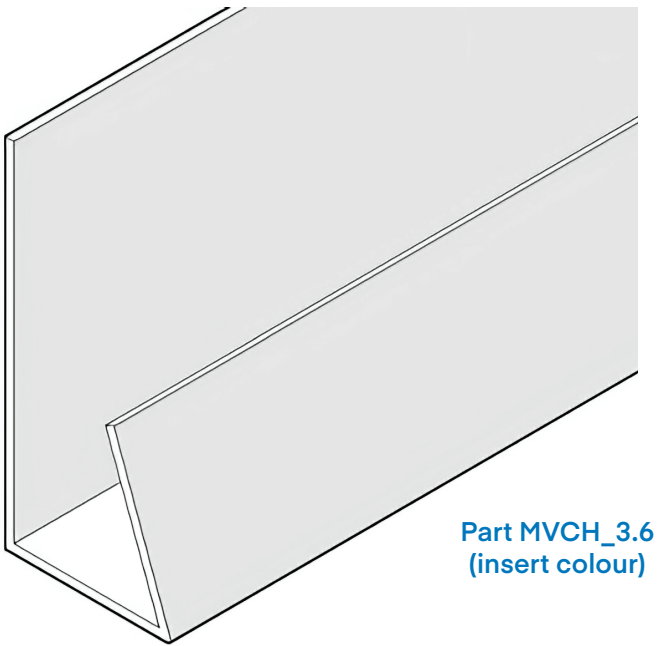

The one-part channel can be used as a vertical trim abutting another cladding but is not ideally suited as a starting option for horizontal part board starts and raked/sloped rooflines. When installed horizontally, 5mm drain holes must be drilled at maximum 600mm centres.

### 2.3.4. Two Part Channel

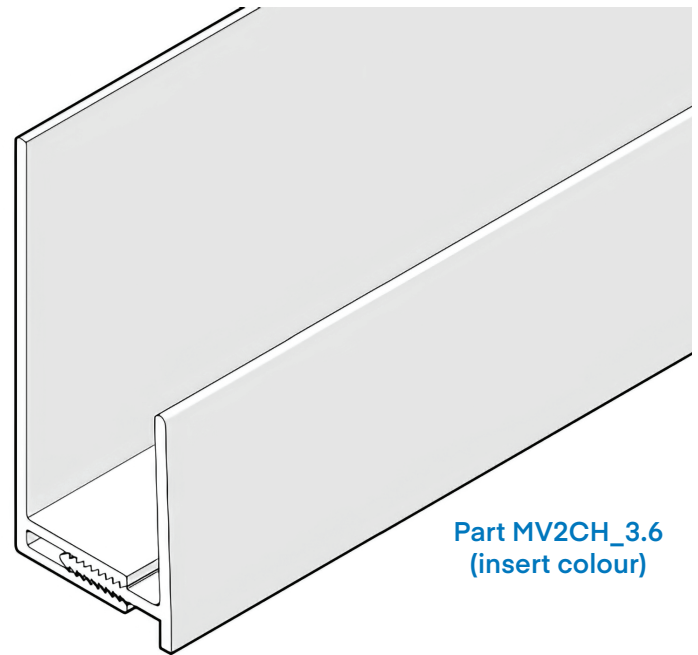

The two-part channel trim can be used as a universal finishing option for both gable ends around the apron of top storeys that contain raked/sloped rooflines or as a vertical trim abutting another cladding. The two-part channel trim cannot be used on horizontal finishes except where modified (refer cut board start).

## 2.4 External Corner Options

### 2.4.1. External 90° Corner Soaker

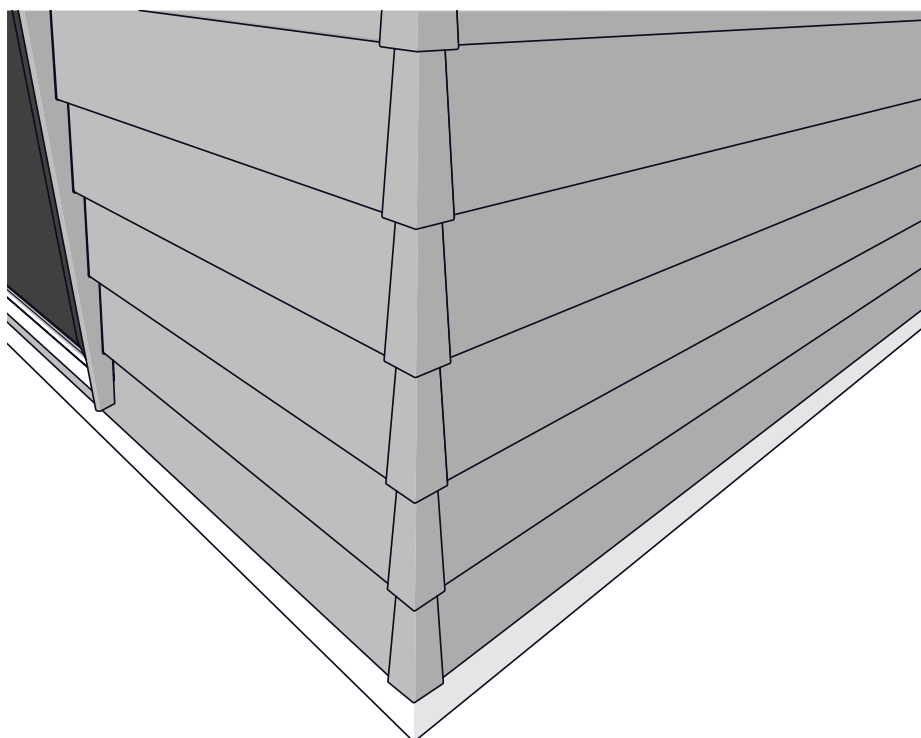

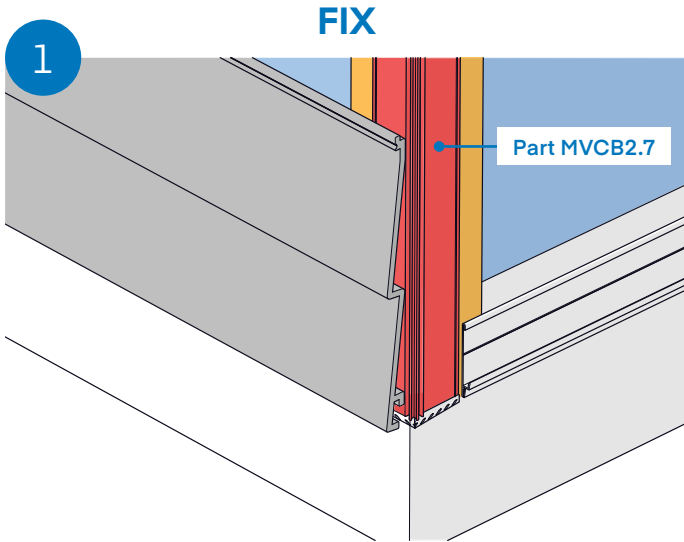

- › Measure and cut base piece to full length
- › Fix corner soaker base prior to board
- › Install weatherboards to ridge on base
- › When joining a two-piece option, stagger the base and cap join

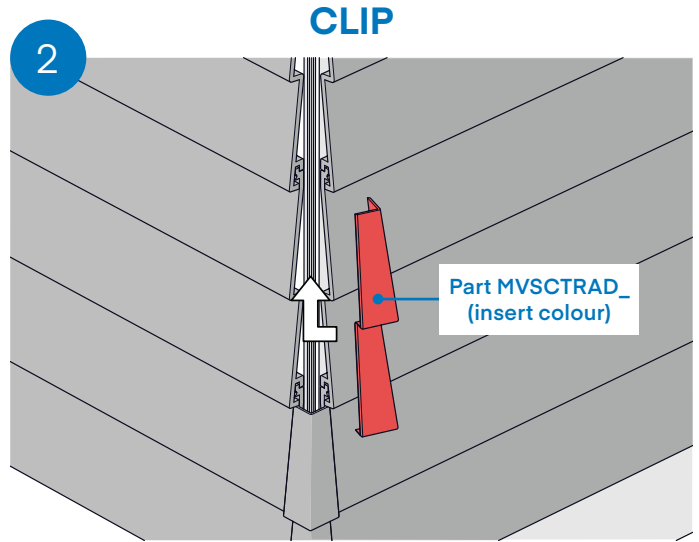

- › After fixing boards, clip corner soaker
- › Ensure that the soakers line up tidily and are pushed up firmly
- › No solvent or sealant is required

## 2.4.2 External 90° Boxed Corner

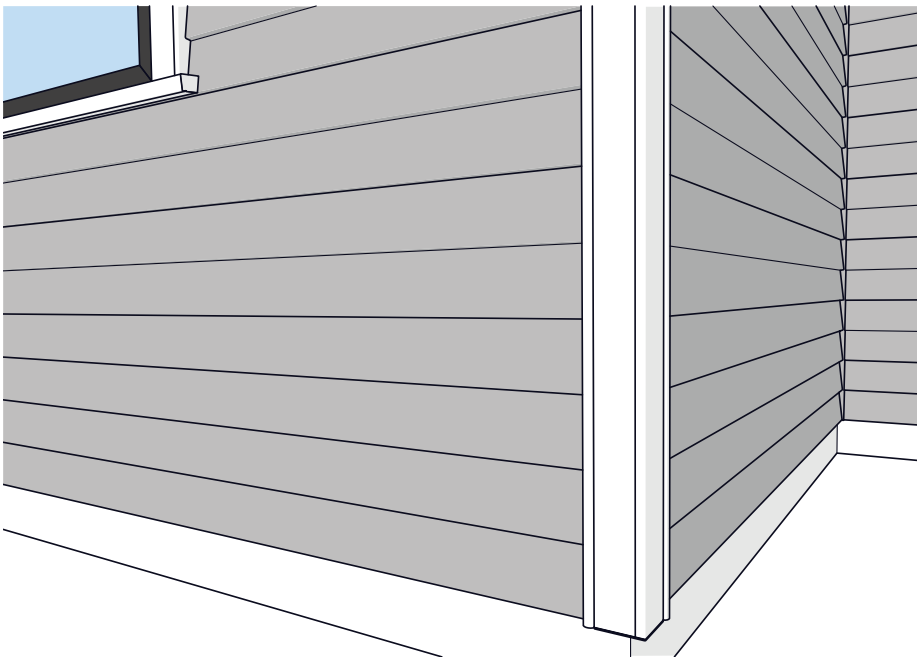

1

### CLIP

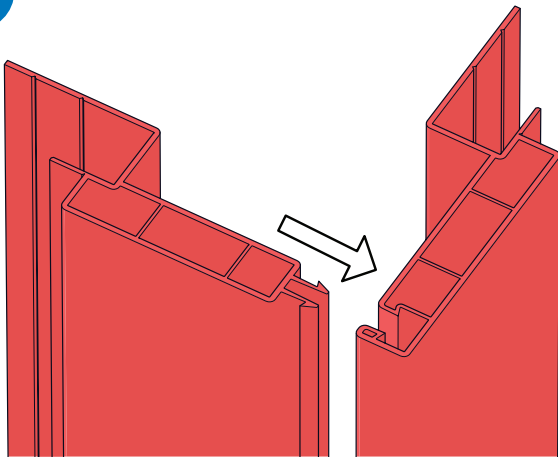

- › Measure & cut male & female lengths to fit full corner
- › Clip together to form box corner
- › There is no requirement for additional back flashings behind the boxed corner

2

### FIX

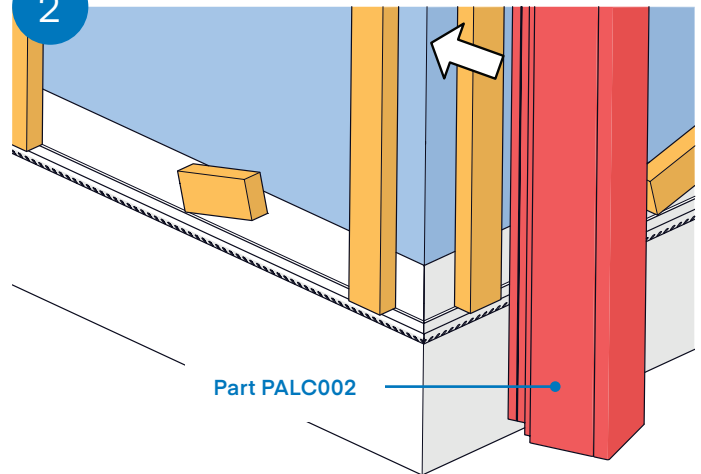

- › Check box corner is square & fix through nailing flange

3

### FIX

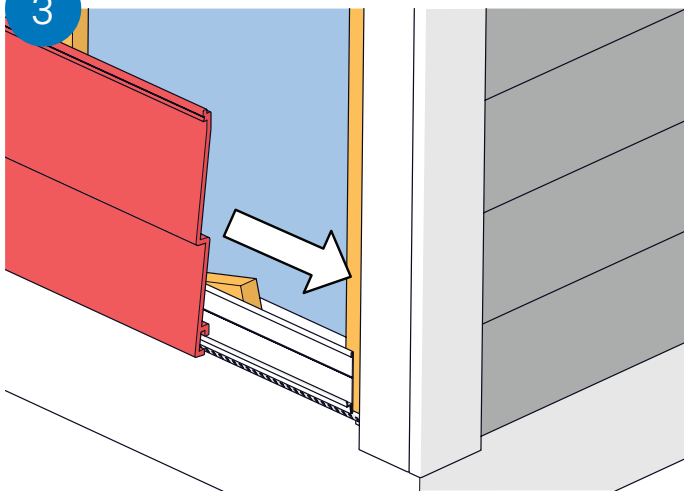

- › Install starter strip level, leaving clearance from the box corner
- › Install weatherboards to box corner (use a scribe as a storey rod)

4

### GLUE

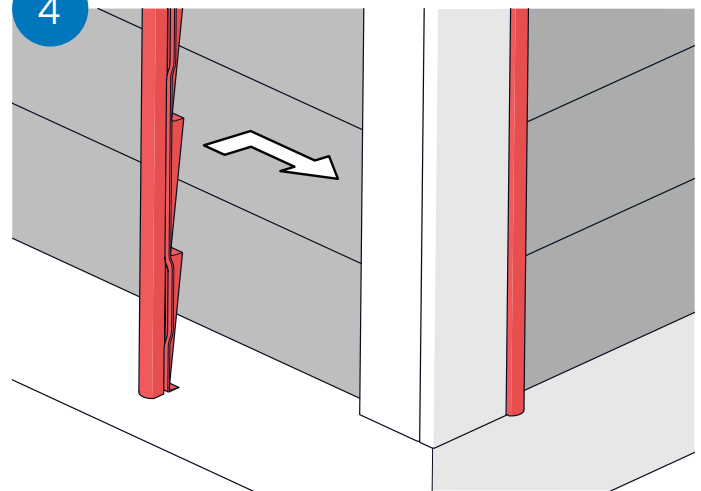

- › Cut and fit scribes to full box corner length
- › Install scribes using a bead of solvent cement along channel in scribe. Only glue scribes to box corner, not board.

5

### FIX

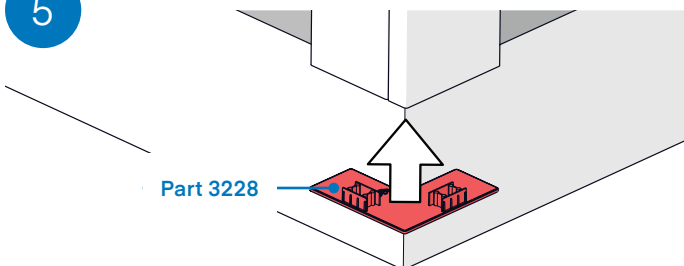

Install bottom box corner cap using solvent cement. Allow a small gap in glue on box cap for drainage.

6

### GLUE

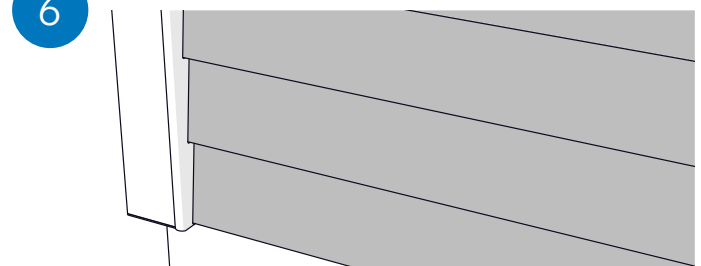

Box corner shown completed with scribes installed both sides and bottom cap to under side.

#### Note:

If a join is required at a box corner, butt two box corner assemblies together using dowels or plugs fashioned from H3.1 treated timber. Stagger the ends of the male and female lengths at the join to add strength.

Where possible, position the join above (or below) eye height.

## 2.5 Internal Corner

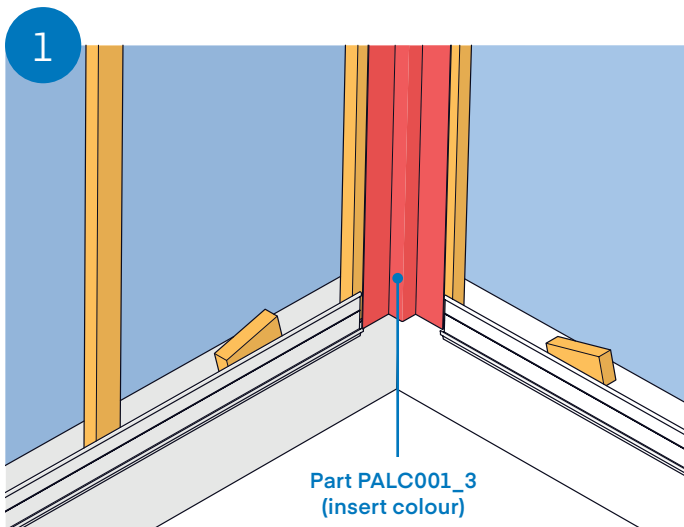
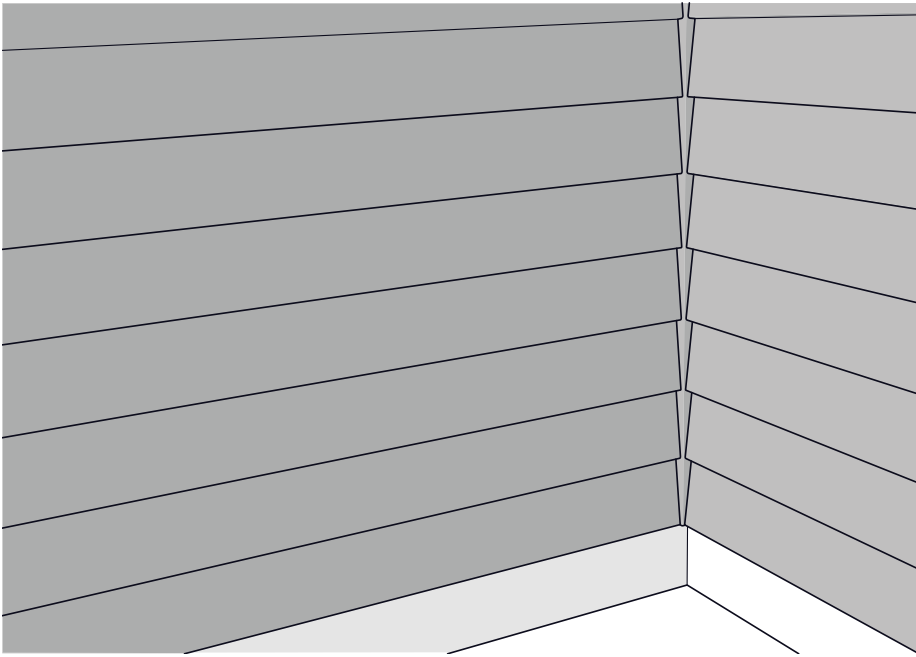

- › Ensure the internal corner flashing is straight and true the full length of the corner

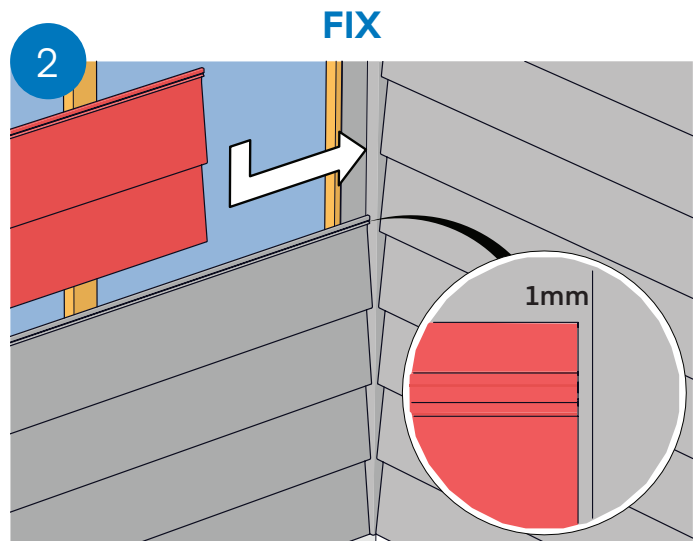

- › Cut weatherboards cleanly fix 1mm from the edge of the internal corner, fixing through board, flashing and into cavity batten
- › During install, check to make sure board courses line up on both sides of the corner

### Note:

If a join is required at an internal corner, butt two one-part internal corner flashings together using a dowel or plug fashioned from H3.1 treated timber. Apply adhesive tape along the join behind the flashing ensuring the tape is pressed down firmly.

Where possible, position the join above eye height.

## 2.6 Non-Standard and 135° Corners

### 2.6.1. Custom Corners

Application specific corners can be manufactured by others and used with Palliside®. A drawing is available showing how to provide custom made back flashings for non-standard corners (refer CAD detail DC-25-T).

### 2.6.2. 135° Corners

A two-part corner accessory is available for 135° corners. This accessory can be reversed to be used on both internal and external corners (refer CAD detail DC-37).

## 2.7 Weatherboard Installation

Once starting heights have been confirmed, building underlay correctly lapped and fixed, cavity battens installed and base accessories have been fixed in place, weatherboards can be installed.

Palliside® weatherboards are double profile and installed bottom up.

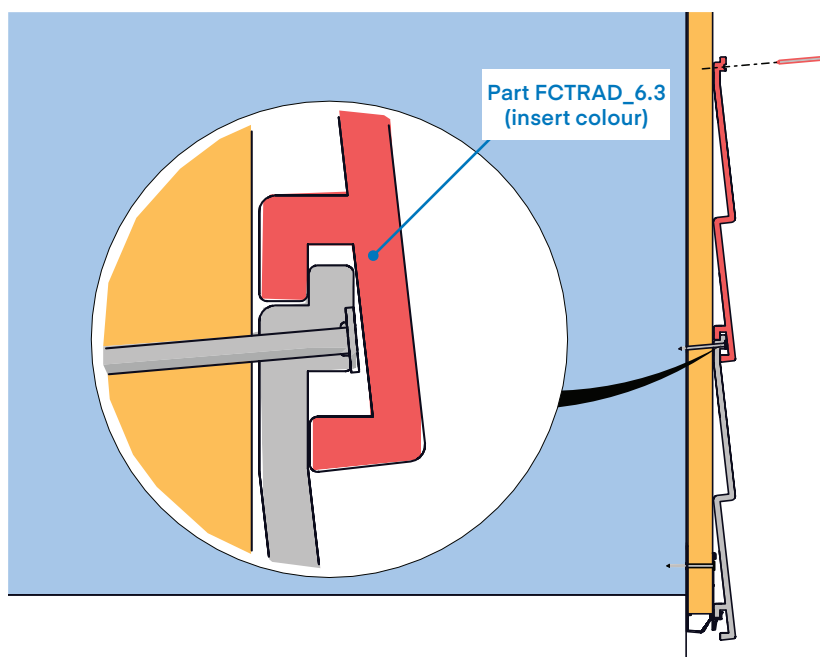

**Note:**

Fix through weatherboard nailing groove angling fixing downward to avoid splitting top of board leading to board creep.

Hit fixing home firmly but do not over nail.

Push next board firmly down and continue fixing. It is critical that boards are aligned and there is no creep at all between boards.

**Note:**

Nail from one end of the board to the other. Or from the middle outwards.

Nail at maximum 600mm centres leaving a 5mm gap between weatherboards (if using the flat soaker jointer).

During installation, regularly check boards are correctly aligned and level.

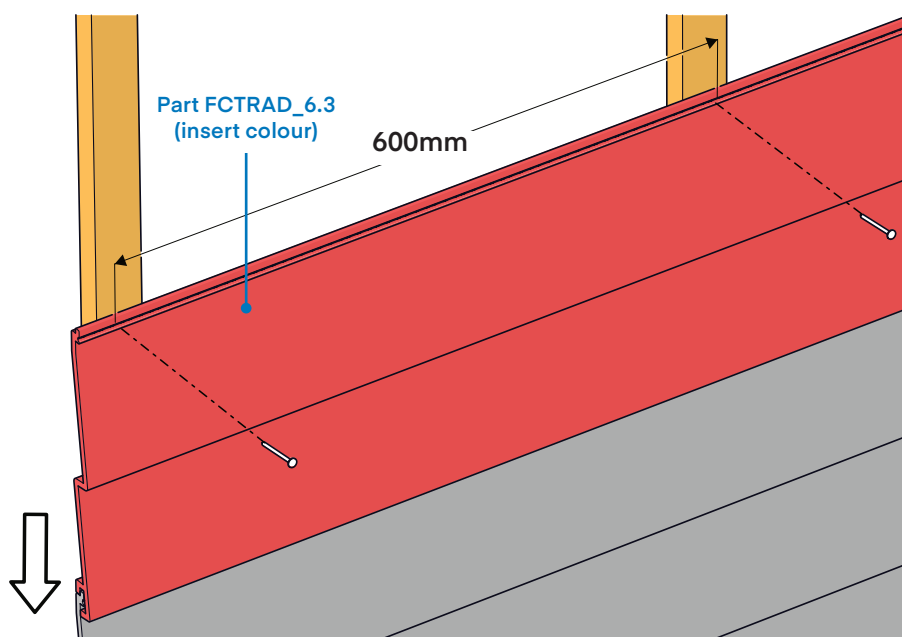

To Assist with interlocking of weatherboards, lay a timber off-cut on the upper edge of the board and gently tap into place with a hammer. Do not hit directly down on top of the weatherboard.

## 2.7.1. Packing Out Cut Weatherboard

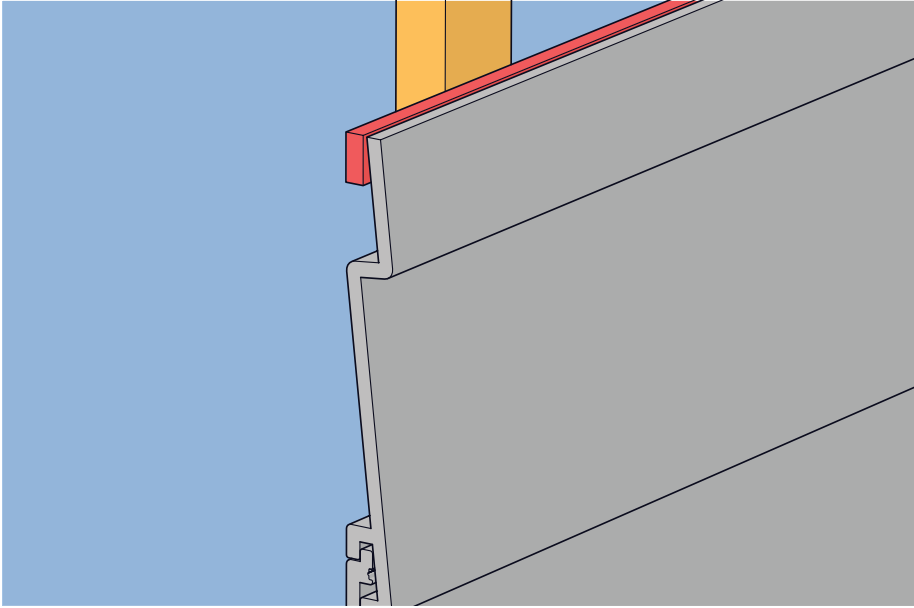

**Note:**

When starting or finishing on a part board or where a part board finishes below joinery, pack out with timber packers.

Any horizontal cut areas will need to be nailed in place at a maximum 600mm centres. Nail these areas so that the fixing is not visible (e.g. covered by joinery or trim).

## 2.7.2. Cut Board Start (Horizontal Only)

Due to the tapered nature of the traditional weatherboard profile, starting part way up the face of the weatherboard may make the area unsuitable for using any of the standard starting trims discussed in this document. Therefore, particular care needs to be taken with the weatherboard cut. If desired, the 2-part channel trim can be used by modifying (reducing) the base and cap to allow the cap to fit tighter to the base. Due to the modification, solvent cement may be required to glue the cap piece in place. Drain holes still need to be drilled to allow moisture to get out.

## 2.8 Jointing Options

Flat soakers, to suit the double profile weatherboard, as well as full length jointers, are available for finishing joins in weatherboard. Flat soakers can be installed off-stud (staggered), while full length jointers require installation to stud.

### 2.8.1 Moulded Flat Soakers

Where possible, join shorter weatherboard lengths on a less prominent section of the building. There is no base piece required for this option.

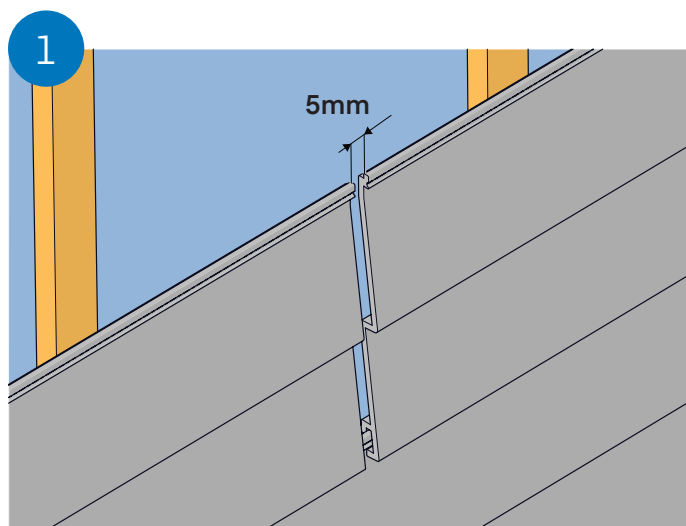
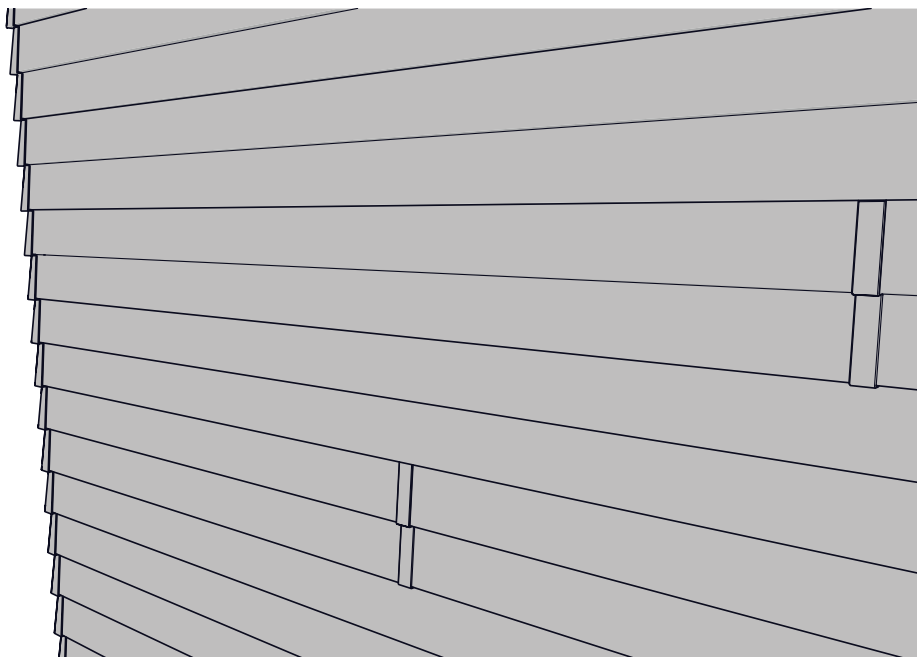

**Note:**

The flat soaker can be inserted after all weatherboards are installed.

- › Leave a 5mm gap when installing weatherboard for thermal movement

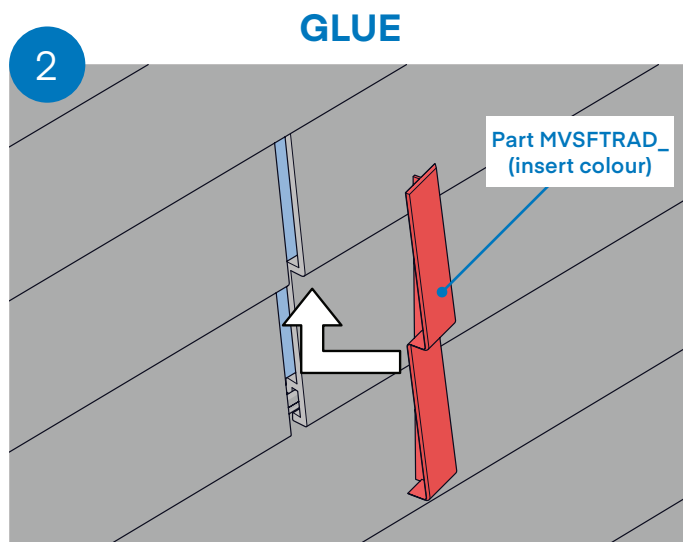

- › Apply solvent to one side of the back fin of the flat soaker and push in place wiping away excess solvent

**Note:**

Do not glue soaker to both boards.



## 2.8.2 Two-Part Jointer

Where possible this jointing option can be strategically placed and covered by a downpipe or similar, and must be installed on a stud.

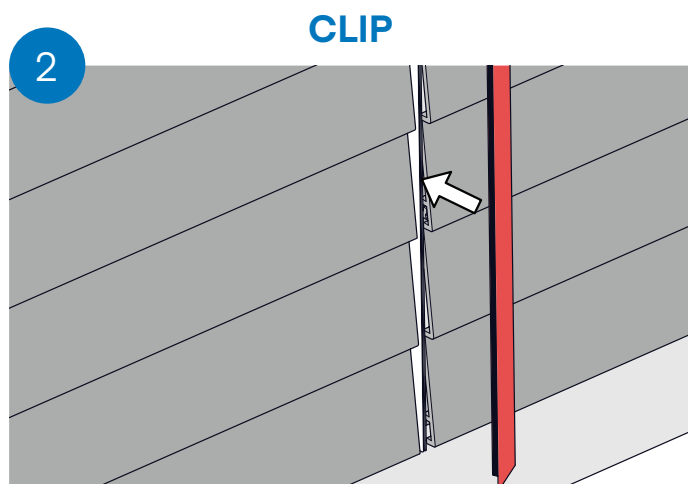
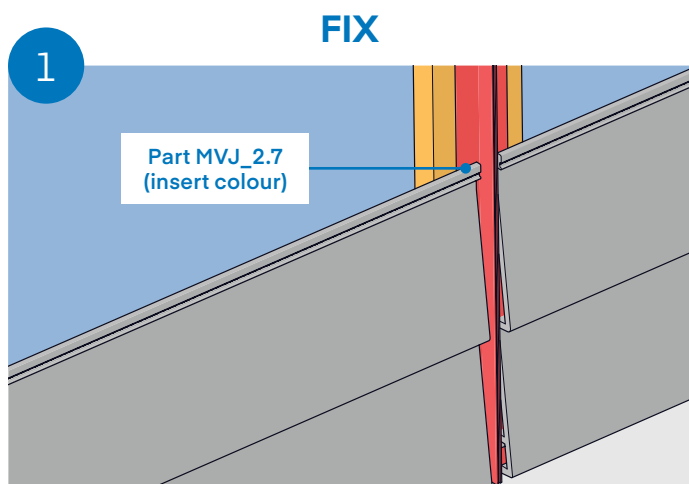
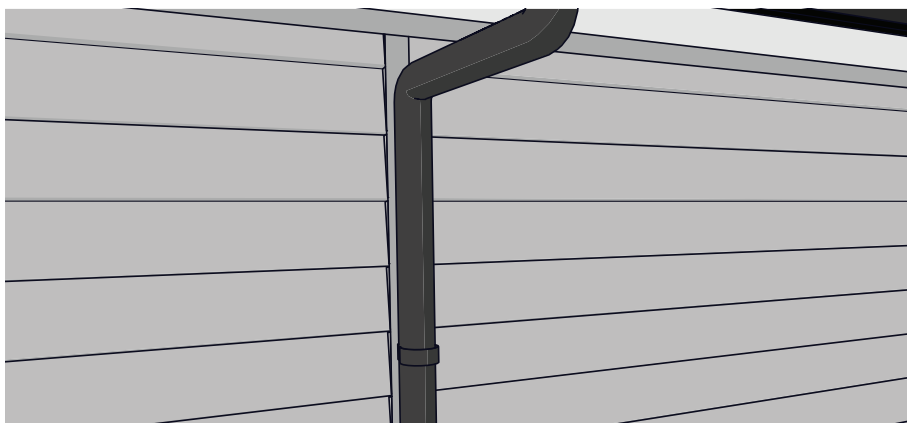

- › Measure and cut female base to fit
- › Fix base piece prior to installation of weatherboards
- › Fix weatherboards 5mm short of the spine of the base piece.

- › Measure and cut cap piece to fit
- › Clip cap firmly in place

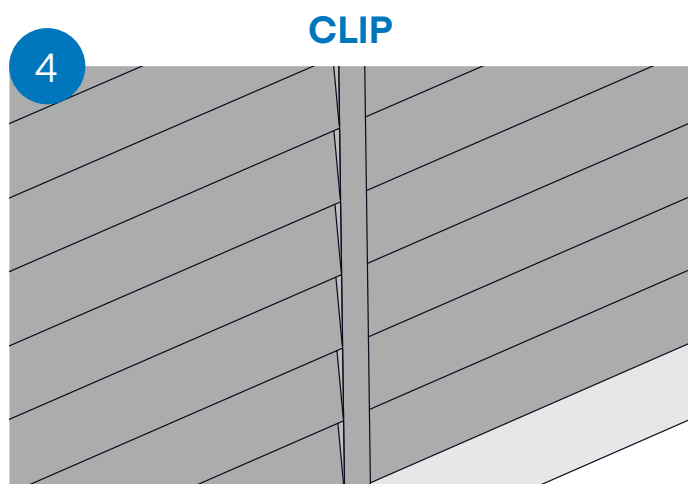
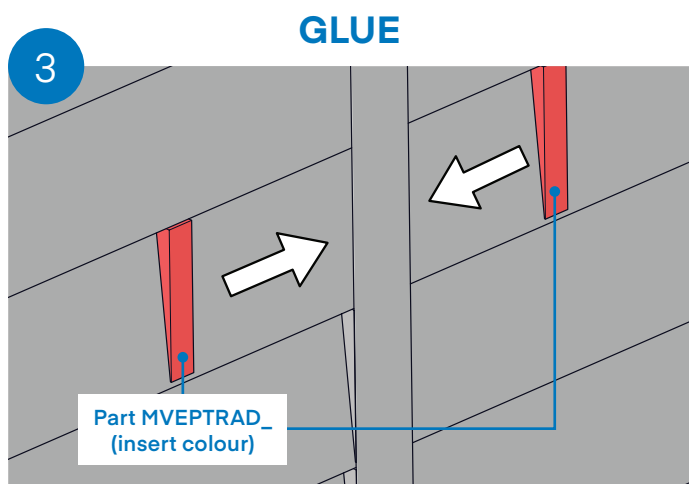

- › Apply solvent to weatherboard face within the gap where end plug is to be placed
- › Insert moulded end plugs to be flush with male cap piece

Jointer shown completed with end plugs installed both sides of jointer.

**Note:** Do not apply solvent to the end plug itself.

## 2.9 Installation at Joinery

### 2.9.1 Installation of Jamb Flashing Base

The vertical jamb flashing base is fixed in place either side of openings. Cut the jamb flashing base to match the height of the opening.

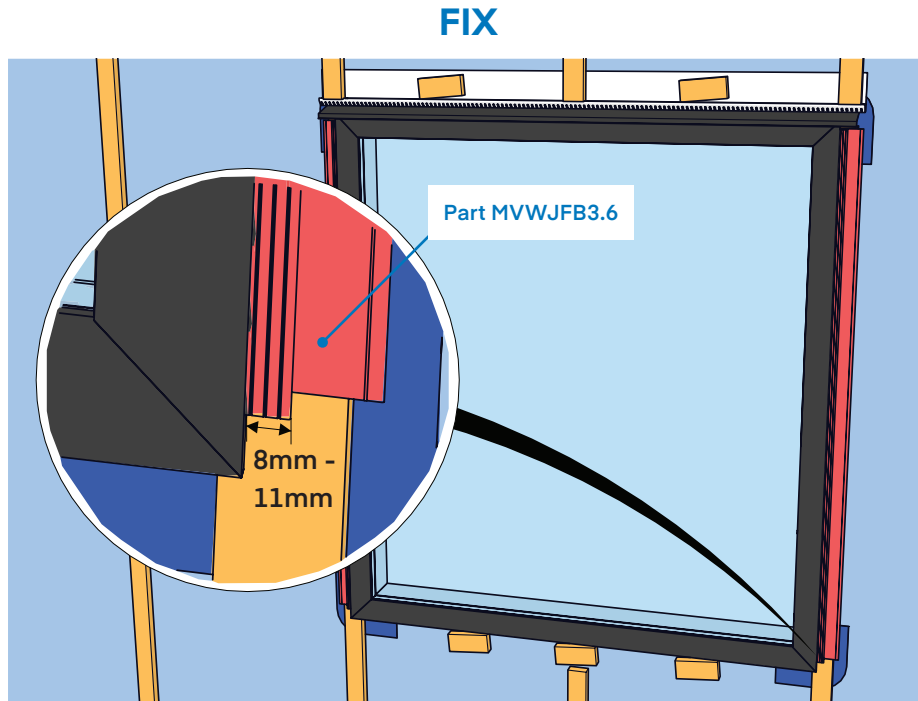

**Note:**

Ensure the jamb flashing is recessed behind joinery flange either side by a minimum of 10mm, and protruding by 8mm to 11mm.

Fix jamb flashing base to cavity battens at 300mm centres

### 2.9.2 Installing Weatherboard at Sill

Carry out installation of weatherboard from the bottom up, cutting the board around the opening to suit, up to head flashing level.

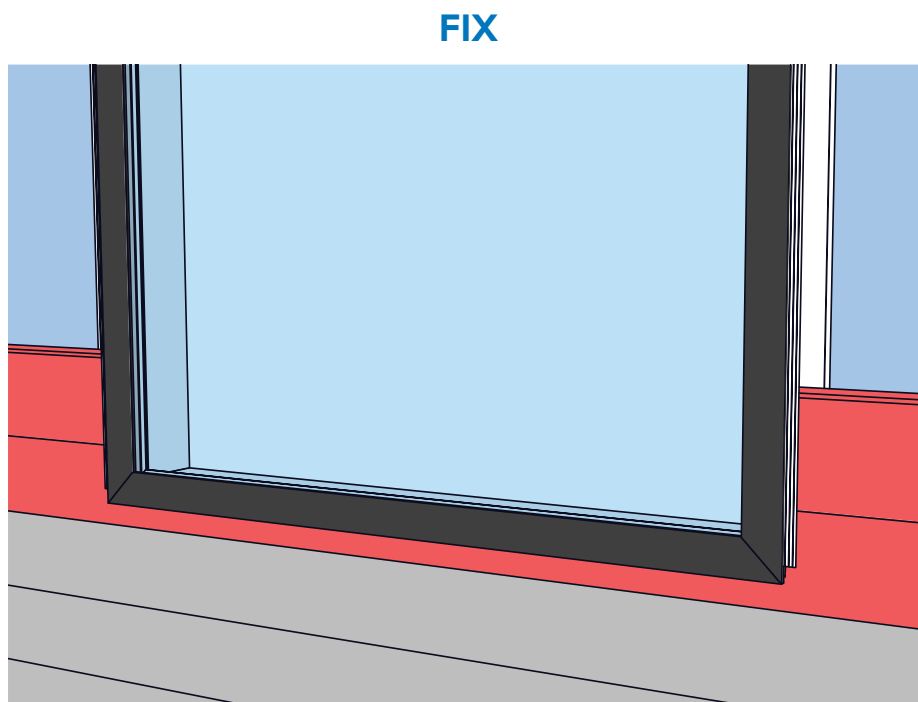

**Note:**

Pack out cut weatherboard at sill and fix at 600mm centres.

### 2.9.3 Part Weatherboard Above Joinery

If the head flashing is located within the double board profile, measure where the head flashing is going to penetrate the face of the weatherboard. Cut the weatherboard out to suit, taking care to ensure that the horizontal cut for the head flashing is neatly finished and will allow the head flashing to sit tidily.

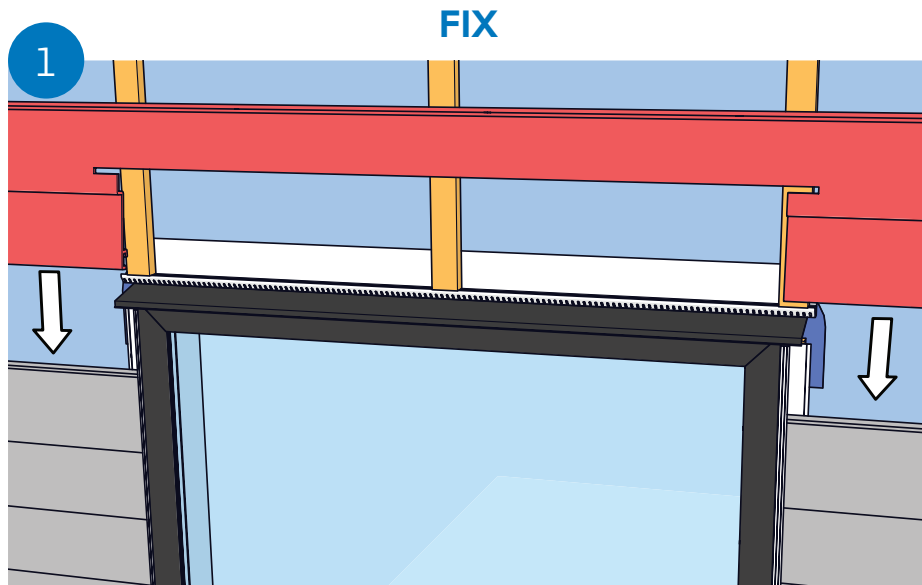

**Note:**

Nail packers behind cut weatherboard, above the head flashing, evenly spaced at maximum 600mm centres.

Angle head flashing cut so that the back of the board is not visible once installed.

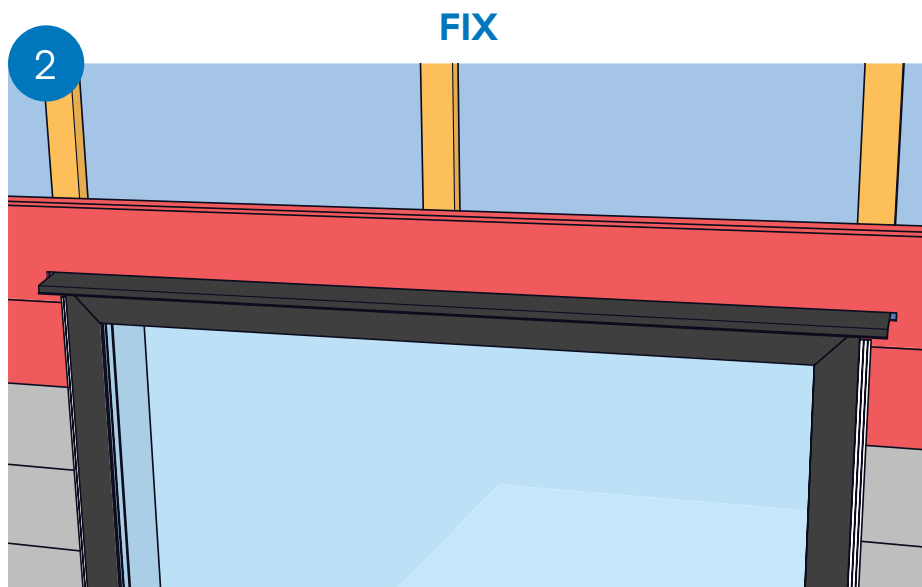

**Note:**

Install weatherboard around head flashing ensuring fully engaged over previous weatherboard and in to jamb flash base.

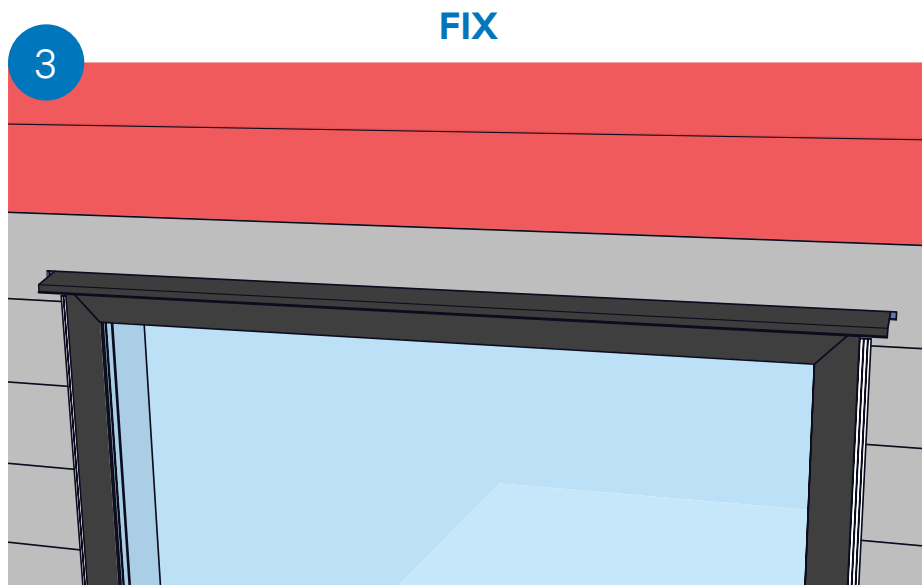

**Note:**

Apply sealant at either end of the head flashing to form a head flashing stop end.

Continue installation of weatherboard above head flashing.

## 2.9.4 Full Weatherboard Above Joinery

If it works out that a full weatherboard profile finishes in line with the head flashing, it will be necessary to cut a slot into the weatherboard either side of the opening to allow for the head flashing. Trim the nailing groove from a weatherboard off-cut, (e.g., taken from the cut around the base of the opening) and fix at the head to support the next board.

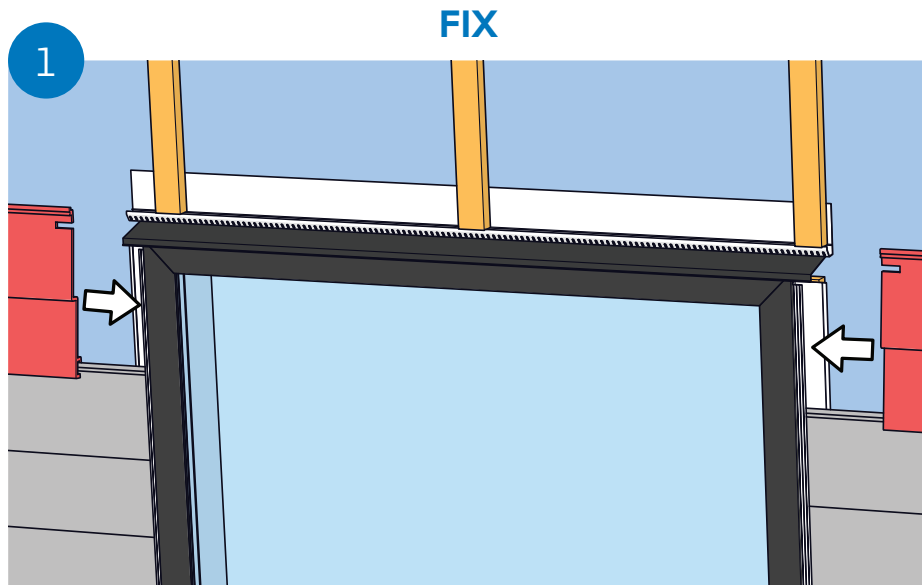

**Note:**

Install weatherboard each side of head flashing ensuring fully engaged over previous weatherboard and in to jamb flash base.

Angle head flashing cut so that the back of the board is not visible once installed.

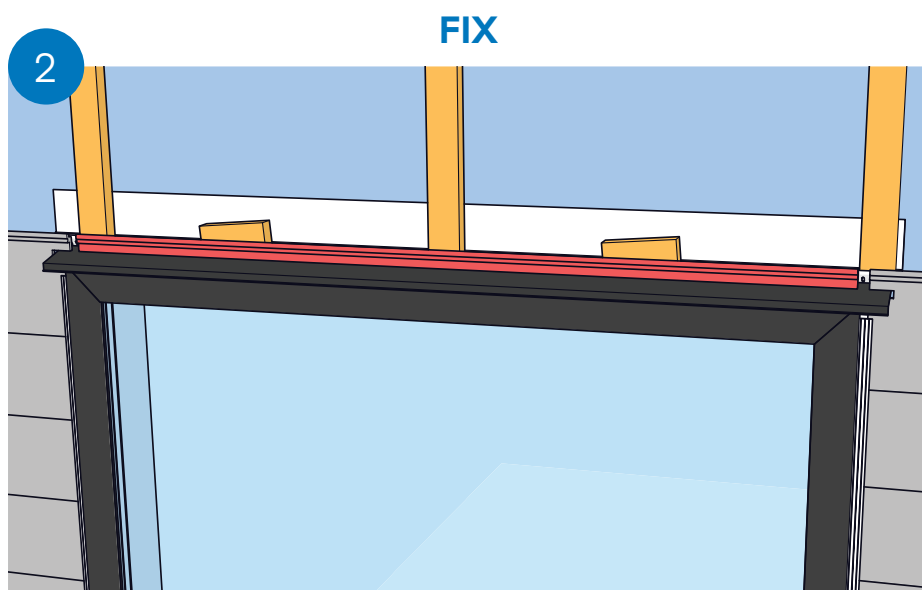

**Note:**

Fix trimmed nailing groove strip across base of head flashing, using packers, level with the nailing groove either side of the opening.

Ensure only the nailing groove portion of the board is used so not visible once the next board is installed.

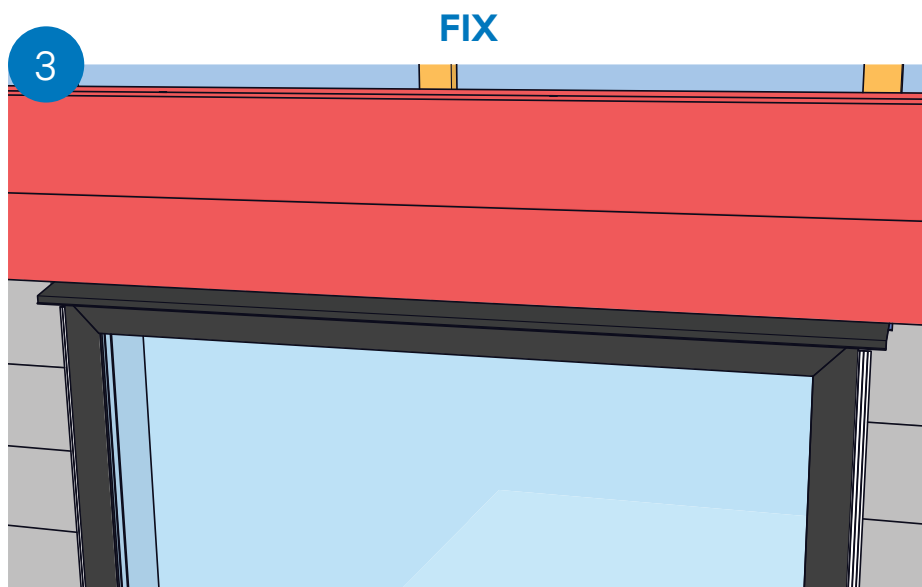

**Note:**

Apply sealant at either end of the head flashing to form a head flashing stop end.

Continue installation of weatherboard above head flashing.

## 2.9.5 Securing Cut Weatherboard Above Head Flashing

In a part board above head flashing application, it is necessary to fix the cut weatherboard in place above the head flashing.

To achieve this, ensure that the weatherboard is correctly packed out and fix these boards using SS304 40x2.8 jolt head nails (alternatively 2x SS304 finishing brads skewed). These fixings must be spaced at maximum 600mm, punched, filled then covered using matching Palliside® finishing paint. Refer CAD detail DC-01-T.

## 2.10 Installation at Soffit

In a part board above head flashing application, it is necessary to fix the cut weatherboard in place above the head flashing.

To achieve this, ensure that the weatherboard is correctly packed out and fix these boards using SS304 40x2.8 jolt head nails (alternatively 2x SS304 finishing brads skewed). These fixings must be spaced at maximum 600mm, punched, filled then covered using matching Palliside® finishing paint. Refer CAD detail DC-01-T.

### 2.10.1 Horizontal Soffit Finish

Horizontal soffit line is finished using the Palliside® foam soffit, a universal 40mm x 18mm cornice moulding, available in 3.6m lengths to match the chosen Palliside® colour.

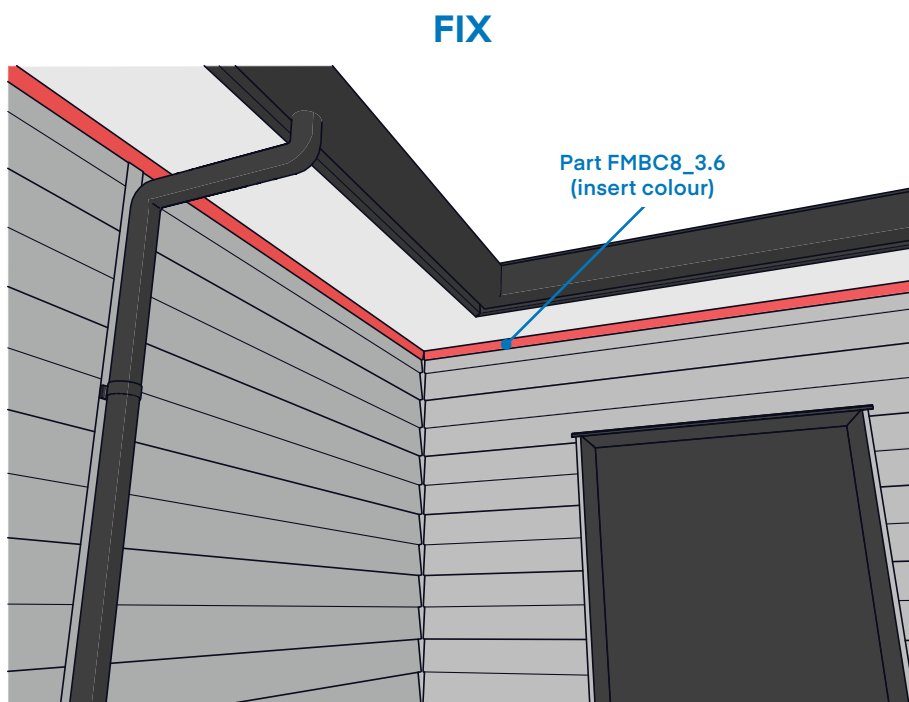

**Note:**

Nail - 40mm x 2.8mm jolt-heads punched, filled, then covered using matching Palliside® finishing paint.

## 2.10.2 Raked or Gable End Soffit Finish

Finish Palliside® Weatherboard so there is a 20mm gap between the board and the rake or gable end. Into this gap fix a continuous timber H3.1 20mm x 20mm packer. For best results pre-paint the packer in a colour similar to the Palliside® board before installing.

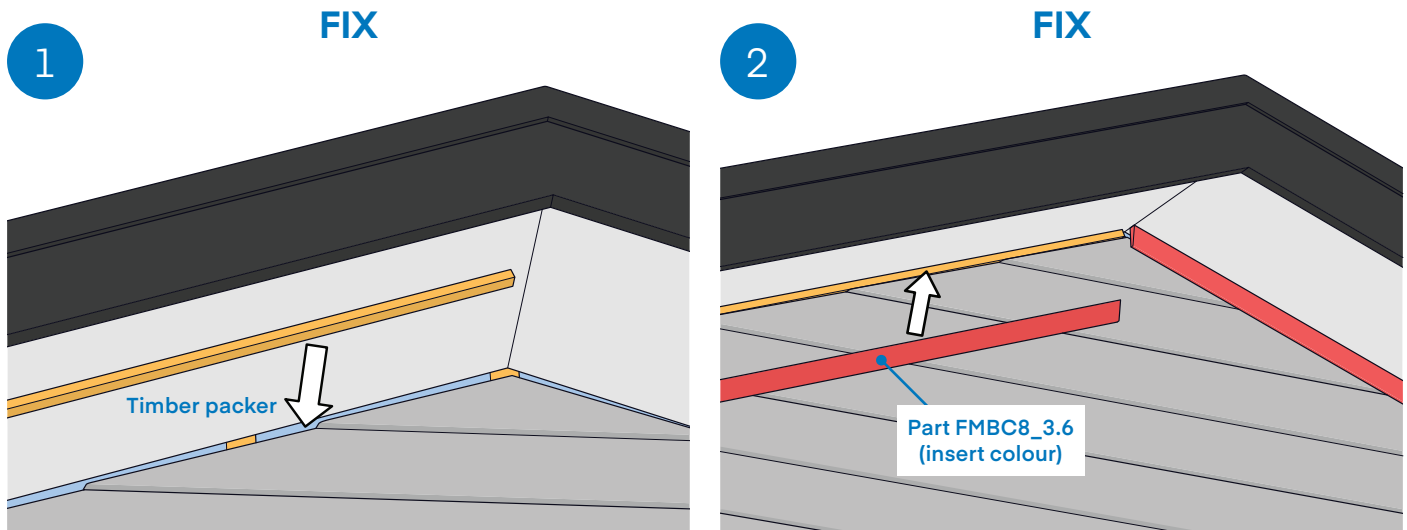

### Note:

Apply a continuous bead of sealant where the board finishes to the edge of the packer. Nail the Palliside® foam soffit mould in place through this packer at 300mm centres using HDG 40mm x 2.8mm jolt heads (or finishing nails with a minimum Class 4 type finish, 2 per fixing point, skewed). Punch the fixings if required, fill, then cover using matching Palliside® finishing paint.

## 2.10.3 Alternative Soffit Finishes

The Palliside® 2-Part Channel Trim can be used as an alternative soffit finish. The base of the 2-part channel needs to be fixed in place prior to the installation of the top weatherboards. Before inserting the cap, insert a continuous strip of Polyethylene Foam (PEF) Rod or Inseal tape placed between the spine of the 2-part channel base and the weatherboard.

Another option is to use an H3.1 timber mould to cut a finishing scribe. Once the scribe has been prepared and fixed in place through the Palliside®, the gaps can be filled with appropriate sealant and the scribe painted.

## 2.11 Below Joinery Finishing Options

### 2.11.1 Under Joinery Bead

Any gaps below joinery greater than 5mm are finished using a low-profile colour matched bead. The bead uses a white base clip fixed directly under joinery (through the weatherboard, packer and in to the cavity batten). This finish can be used under windows as well as doors and ranch sliders.

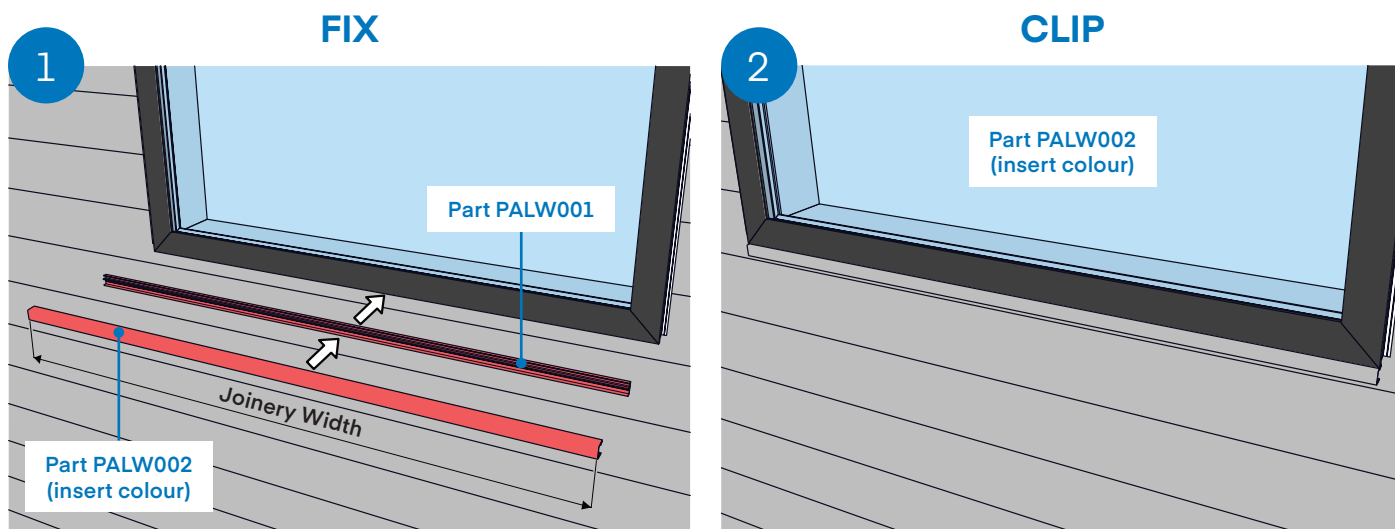

- › Cut Palliside® under window base clip and colour matched cap to match width of joinery
- › Fix base in place directly below joinery through the fixing groove using class 4 or above 8Gx20 pan head screws at 300mm centres
- › Clip the colour matched cap firmly in place over window base ensuring clip is fully engaged. Ensure cap is central before clipping

## 2.11.2 Full Planted Sill

Pallside® includes an optional Under Window Planted Sill to finish under joinery. The sill uses a white base clip fixed directly under joinery (through the weatherboard, packer and into the cavity batten). The full sill is for use under windows only, not for use under doors and ranch sliders. If using window facings, refer to the separate facings installation guide.

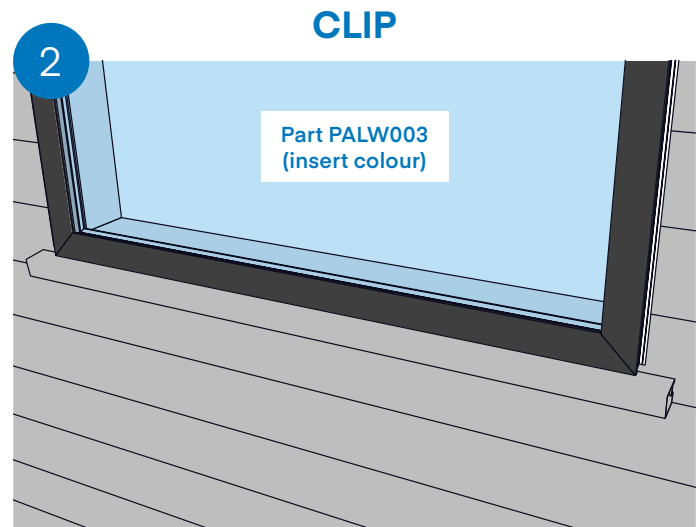
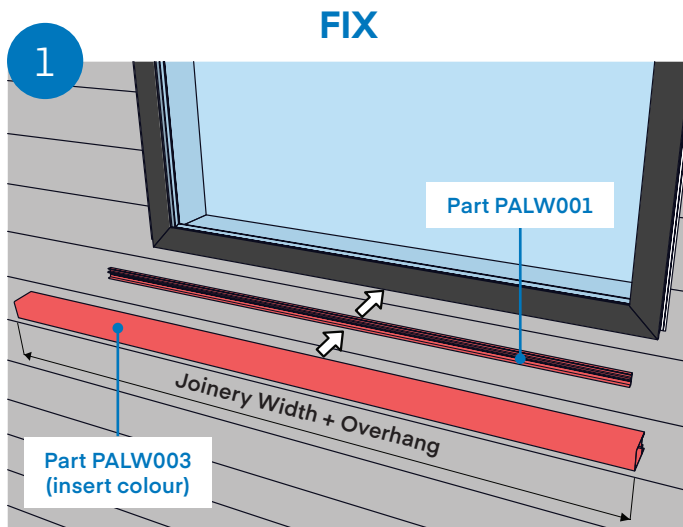

- › Cut Pallside® under window base clip to width of joinery
- › Cut Pallside® planted sill to allow overhang each side of joinery
- › Fix base in place directly below joinery through the fixing groove using class 4 or above 8Gx20 pan head screws at 300mm centres

- › Clip the sill firmly in place over window base ensuring clip is fully engaged. Ensure sill is central before clipping
- › Fix sill at one side of joinery (inside the sill out of sight) to avoid movement

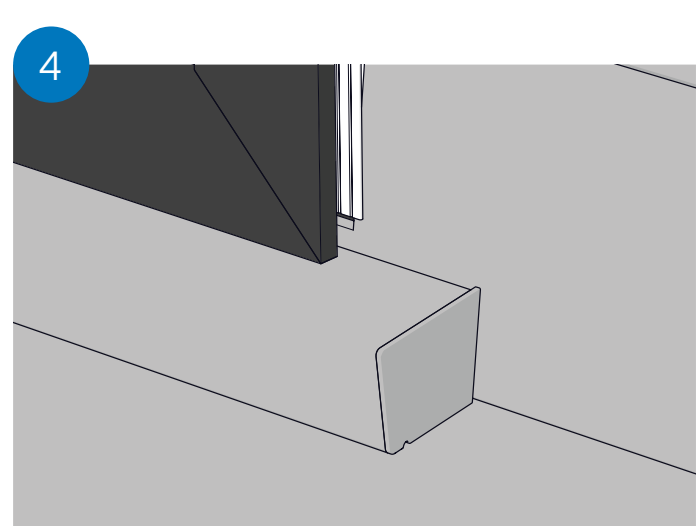
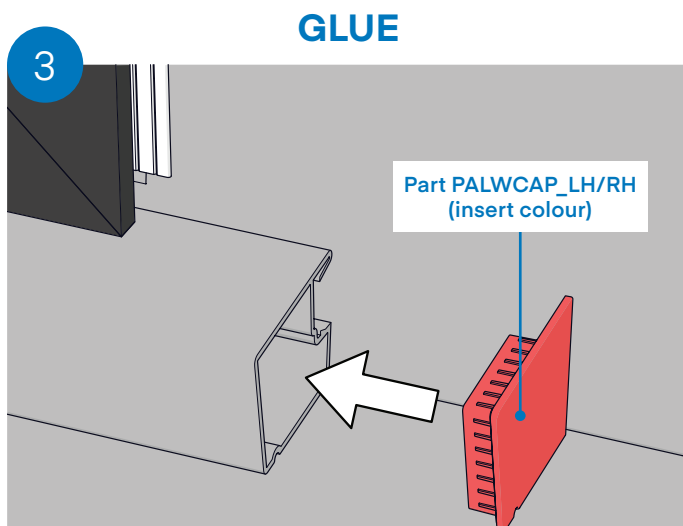

- › Modify handed sill caps if required (by removing extension tabs) to fit against weatherboard

- › Glue caps each side to sill ends using solvent cement



## 2.12 Joinery Finishing Options

### 2.12.1 Pre-Cut Scriber

Pallside® pre-cut scribes come handed and in a range of colours to match or compliment the weatherboard.

#### MEASURE

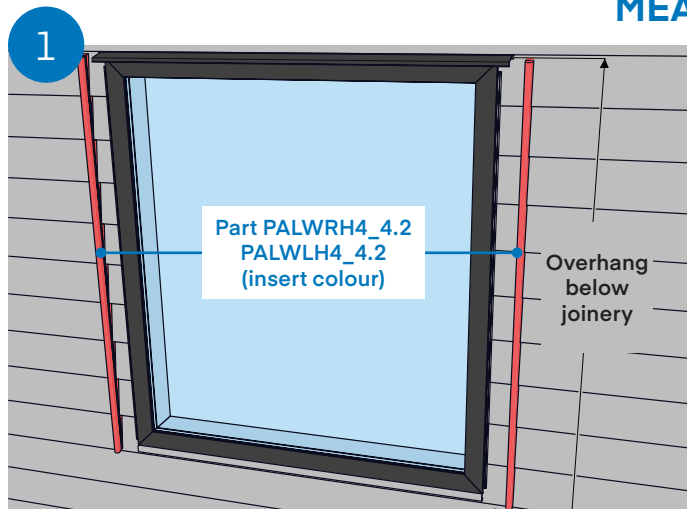

Measure and cut scribes for under window bead option

- › Hold scribe firmly in place and mark angle at head flashing. Cut scribes to continue below joinery to cover hollow end of low-profile bead

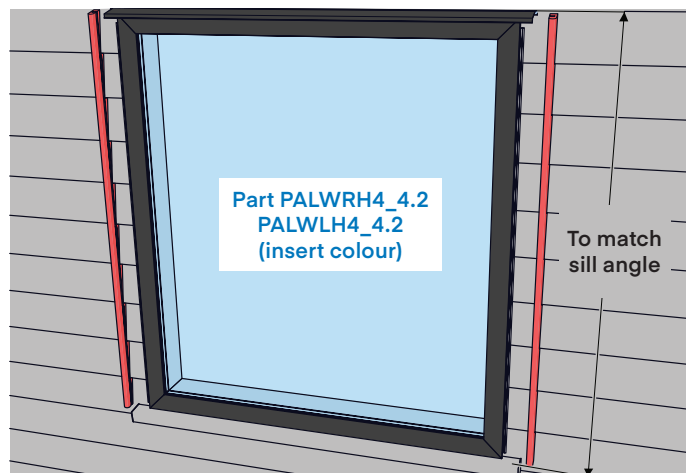

Measure and cut scribes for under window full planted sill option

- › Hold scribe firmly in place. Mark and cut to match angle at head flashing and angle at sill

#### GLUE

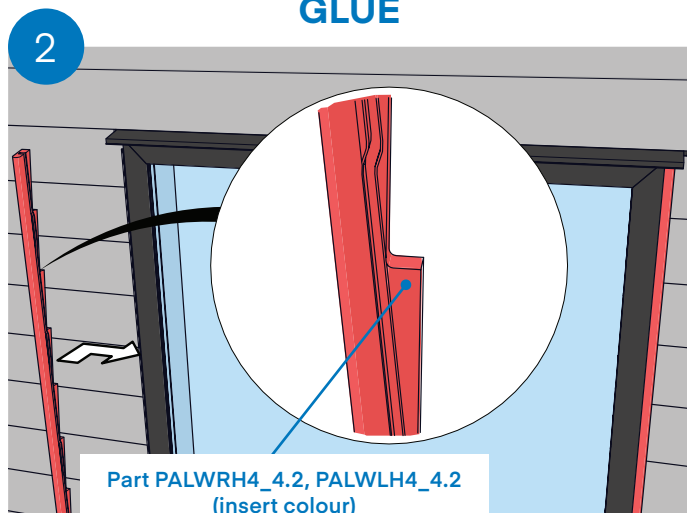

- › Apply a continuous bead of solvent cement to the scribe groove
- › Glue scribes in place both sides of joinery

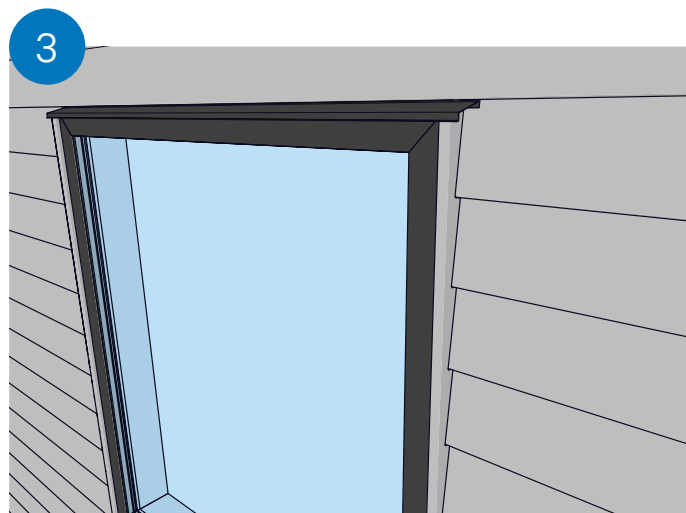

- › Ensure scribes are pressed firmly towards joinery and up against the board profile to ensure a good bond

#### Note:

In situations where joining scribes is required, mark out where to cut the scribe and cut both scribes at the same point in the profile.

Ensure the cut is accurate so the scribe pitch remains 129.5mm exactly.

## 3.0 Additional Installation Information

### 3.1 Solvent Cement

Solvent cement is mainly used for fixing Palliside® end plugs and flat soakers in place:

- › When using solvent cement, care should be taken to avoid any solvent being placed on the parts of extruded PVC accessories that are visible such as the caps of boxed corners and channel trims (this can lead to dimpling).
- › Excess solvent should be removed straight away by using a damp rag. Do not wait for solvent to dry before doing this.
- › Be aware that Palliside® solvent cement takes time to adhere therefore apply solvent and wait a short time before installing end plugs or flat soakers.
- › Apply solvent to gap where end plug is to be placed; do not apply solvent to the end plug itself.
- › Apply solvent to one side of the flat soaker and push in place wiping away excess solvent.

A range of MS-based sealants matching the Palliside® colours are available. These, and other neutral cured or silicon-based sealants can be applied to Palliside® in the following scenarios:

- › To form a flashing stop-end above joinery.
- › Around the area where the head flashing penetrates the weatherboard to the sides of joinery.
- › Finishing around penetrations such as pipes, etc.

**Note:**

The use of solvent cement or sealant should not substitute the use of sound weathertightness principles and/or tidy finishing.

### 3.2 Finishing Paint

If required, trims etc. can be colour-matched to the Palliside® colours. Matching paint formulations can be made up by your local paint manufacturer. It is also possible to get a spray can of colour matched spray paint for all Palliside® colours. Refer to the Palliside® Technical Guide for more information on colour matching.

### 3.3 Steel Frame Configuration Table

Fixings for Palliside® - Drained Cavity Steel Frame		
Palliside® configuration	Palliside® weatherboards installed over cavity to steel frame where the cavity batten has an r value of <math>r < 0.25</math>	Palliside® weatherboards installed over cavity to steel frame where the cavity batten has an r value of >math>r > 0.25</math>
Requirement	Palliside® must be fixed to steel frame over a cavity batten and a thermal break	Palliside® fixed over a cavity batten which contains an R value of >math>R > 0.25</math> and a horizontally fixed thermal break that does not block off the cavity ventilation and drainage
Framing	Steel Framing in accordance with NASH3405 and specific design to meet requirements of NZBC	Steel Framing in accordance with NASH3405 and specific design to meet requirements of NZBC
Thermal break - vertical framing members	As per vertical fixing	A thermal break in accordance with NZBC Acceptable Solution E3/AS1 with an R-value of >math>R > 0.25</math> must be fixed to each horizontal framing member. This must have a structure that allows for drainage and ventilation of the cavity (i.e. has passed an E2/VM1 test or has a maximum depth of 12 mm)
Building underlay meeting requirements of nzbc acceptable solution e2/as1, table 23	A building underlay meeting requirements of NZBC Acceptable Solution E2/AS1, Table 23, must be installed between the thermal break and cavity batten	A building underlay meeting requirements of NZBC Acceptable Solution E2/AS1, Table 23 must be installed directly to the framing, behind the cavity batten
Cavity battens	Must meet durability requirements of B2/AS1 and be minimum 45mm wide with 20mm nominal thickness (18mm minimum). Installed over the thermal break	Must meet durability requirements of B2/AS1 and be minimum 45mm wide with 20mm nominal thickness (18mm minimum)
Fixings	Class 4, self-drilling, 8-gauge, countersunk, square drive screw (or equivalent). The length of the screw must allow for a minimum 10mm penetration through the framing	Class 4, self-drilling, 8-gauge, countersunk, square drive screw (or equivalent). The length of the screw must allow for a minimum 10mm penetration through the framing

## 3.4 Additional Details

### 3.4.1 CAD Details

A range of specific CAD details are available for access from the Palliside® website, including windows and doors, corners and joins, starts and finishes and other junctions, penetrations and features.

### 3.4.2 Meter-box Head Sill and Jamb

Ensure that the installation of the meter-box is carried out in accordance with the appropriate details (refer CAD details DC-13-15).

### 3.4.3 Palliside® to Brick Veneer Junction Details

When installing Palliside® weatherboards in combination with brick veneer a range of junction details (internal corner, external corner, brick sill, inter-storey and vertical join) are available. These details provide a suggestive means of flashing between these claddings. Other methods may be adopted providing that they demonstrate sound weathertightness principles. If in doubt speak with the designer, consult your local BCA or phone Dynex Extrusions Limited for guidance (refer CAD details DC-25 to 30 and DC-48 to 56).

### 3.4.4 Palliside® Installed above Joinery Between Brick

This detail sets out the method of installing Palliside® weatherboard above joinery between brick veneer (refer CAD detail DC-31-T).

### 3.4.5 CAD Details

Refer to the Palliside® Technical Guide to see whether there is a requirement for this junction (refer CAD detail DC-42-T).



## Contact Details

For further information visit the website [palliside.co.nz](http://palliside.co.nz) or alternatively contact:  
DYNEX EXTRUSIONS LTD PO BOX 19-133, Avondale 1746, Auckland, New Zealand.

Freephone **0800 439 639**

All material contained within this document is copyright ©2024 Dynex Extrusions Ltd.  
No part thereof may be reproduced without the permission of Dynex Extrusions Ltd.

## Building towards a better tomorrow

The environmental impact of our daily choices is an important consideration for Dynex. We are committed to supplying products and services that are in accordance with the principles of environmental sustainability. Dynex PALLISIDE® is made from 100% recyclable material. We have a policy of recycling all internally-generated scrap material so that nothing is sent to landfill.

Dynex has a goal to reach 100% renewable electricity by 2025 by leveraging Meridian Energy's Certified Renewable Energy programme.



**DYNEX**  
**PALLISIDE®**

0800 439 639 | [palliside.co.nz](http://palliside.co.nz)

**alixis**